



# Bob's Space Racers

**Attendant Free  
Group Games**

**FEC Models**





**Bob's Space Racers**

427 Whac-A-Mole Way

Holy Hill, FL 32117

Phone: 386-677-0761

# Common FEC (Attendant Free) Group Game Questions and Answers

***WWW.BOBSSPACERACERS.COM***

Call or email our sales team at:

Phone: 386-677-0761

Email: [sales@bobsspaceracers.com](mailto:sales@bobsspaceracers.com)



## **Bob's Space Racers**

427 Whac-A-Mole Way

Holy Hill, FL 32117

Phone: 386-677-0761

## Common FEC (Attendant Free) Games Questions and Answers

### **What is a BSR FEC Model and why is it different than other redemption games?**

FEC Group Games are Amusement Park Model Games designed to work in an arcade without an operator.

The BSR FEC Group Games are different because they do NOT cut up the pie with your existing redemption games.

It is unknown to most people that do not have these games; the ability of these FEC's to capture an incremental cash flow that adds tremendous value to your FEC Center.

We truly want to give you a great tool to get an incremental cash increase in your business outside of the regular redemption center or normal games and attractions (Go Carts, Mini Golf, Laser Tag) that are currently in place at your FEC Center.

### **How is the FEC Group Games different than other BSR Group Games for Amusement Parks that require operators?**

For years FEC operators have tried to implement park type games into their facility without much success.

The problem we have found is the inconsistency and cost of the operator.

You can find employees to run your Go Carts, Putt Putt Golf, and Laser Tag, but for some reason when it comes down to park model games for the FEC, it is difficult to find a consistent operator.

Recognizing that, BSR has eliminated all aspects of having to deal with an operator.

The game now has a built in feature that allows it to operate automatically as if there were an operator in the game.

The game dispenses its own special 2"x 4" tickets as if it were dispensing a prize.

***WWW.BOBSSPACERACERS.COM***

Call or email our sales team at:

Phone: 386-677-0761

Email: [sales@bobsspaceracers.com](mailto:sales@bobsspaceracers.com)



## **Bob's Space Racers**

427 Whac-A-Mole Way

Holy Hill, FL 32117

Phone: 386-677-0761

### Common FEC (Attendant Free) Games Questions and Answers

#### **Why does my location need a FEC, I have enough games now – Why would I want another game just to split revenue?**

Adding a FEC Group Game is NOT like adding another redemption game to the mix and attempting to increase your incremental revenue by adding more games. Rather it is creating an entirely different business model for generating cash to your facility.

#### **I Like the Game but the Price Scares Me...**

When customers see the game they usually like the game and the concept but are unsure about the price and it sometimes scares them off.

Our philosophy is that “How Do You Know Its Too Expensive Until You See How Much Money It Can Make For You and Your Facility?”

You can't judge a game until you know how much ROI (return on investment) you have on any piece of equipment.

The BSR advantage on the FEC Group Games is that we DO KNOW the potential revenue that these games generate and are currently making now.

#### **What makes the FEC so different and why does it produce so much revenue?**

The FEC Group Games find the niche that is missed between the attractions and games that are currently in operation at your facility and will increase the cash flow dramatically without taking from your current attractions.

***WWW.BOBSSPACERACERS.COM***

Call or email our sales team at:

Phone: 386-677-0761

Email: [sales@bobsspacracers.com](mailto:sales@bobsspacracers.com)



## **Bob's Space Racers**

427 Whac-A-Mole Way

Holy Hill, FL 32117

Phone: 386-677-0761

## Common FEC (Attendant Free) Games Questions and Answers

### **How Much Knowledge is Needed to Properly Operate in my Location?**

All you need to increase your business sales is a good location that has a good traffic flow and the correct merchandise.

Putting the correct pricing on your FEC Game and placing it the right location where there is a strong traffic flow maximizes the production of the incremental cash flow for FEC Group Games.

It is NEVER a good idea to place these games in the back of your facility to draw a crowd.

You want as many customers as possible to see that this game puts merchandise in their hands in a quick and consistent way.

Putting prizes in your player's hands fuels the desire for others to play and win a prize of their own.

### **How Will The FEC Fair Against My Other Games?**

The FEC Group Game ran properly should be the #1 game at your facility and set the bar higher than any other game in your current operations.

The FEC games have what it takes to become revenue-producing GIANTS for your facility.

Again, the FEC Group Games are stand alone games that should not cut up the pie with your current arcade games if operated properly.

***WWW.BOBSSPACERACERS.COM***

Call or email our sales team at:

Phone: 386-677-0761

Email: [sales@bobsspacracers.com](mailto:sales@bobsspacracers.com)



## **Bob's Space Racers**

427 Whac-A-Mole Way

Holy Hill, FL 32117

Phone: 386-677-0761

## Common FEC (Attendant Free) Games Questions and Answers

### **How should the merchandise for this FEC Group Game be distributed?**

The winner takes the ticket to the redemption center to receive their prize and then proudly carries their prize around your center.

Many games give out tickets to be redeemed for prizes, but the FEC is truly the only game that allows your players to win a prize with just one play and quickly distributes the merchandise.

The more merchandise (prizes) that is distributed to your players, the more customers will seek out the game that is giving out the prizes and the more money the game will make.

The merchandise of the FEC does not interfere in any way with the merchandise from the redemption center.

The FEC is a completely different business model that adds to the desire of people to want to win more prizes and have prizes in their hands, therefore creating substantial incremental cash flow for your facility.

### **Getting The Price Right For Your Merchandise**

It is key to get the right pricing and correct sizes of merchandise for your FEC Group Game.

We can give you support in getting the correct merchandise to maximize your revenue from the game.

These games produce a lot of revenue and give away a lot of prizes therefore we need our customers to be receiving wholesale prices rather than retail prices. We can help you with that.

***WWW.BOBSSPACERACERS.COM***

Call or email our sales team at:

Phone: 386-677-0761

Email: [sales@bobsspaceracers.com](mailto:sales@bobsspaceracers.com)



**Bob's Space Racers**

427 Whac-A-Mole Way

Holy Hill, FL 32117

Phone: 386-677-0761

# FEC (Attendant Free) Group Game Model Information

***WWW.BOBSSPACERACERS.COM***

Call or email our sales team at:

Phone: 386-677-0761

Email: [sales@bobsspaceracers.com](mailto:sales@bobsspaceracers.com)



# WATER GUN FUN PIXEL PLAY

www.bobsspacers.com

## **Water Gun Fun™ Pixel Play™; 5 Player FEC Model Group Game Attendant Free**

### **Features:**

- Water Gun Fun Pixel Play FEC Model can utilize specialized 2" x 4" redemption tickets or standard 1" x 2" tickets.



- Low maintenance water system.
- Secure display shelves.
- Overhead lighting and custom pixel theme features.

### **Game Play:**

- Operates without an operator.
- The game is pre-wired to utilize any card swipe system to coin up a game.
- Once a player coins up, the game will begin to count down to start the race.
- Countdown timer resets once another player coins up.
- When countdown timer reaches "0", the race will start.
- Players race their toys to the finish line. First player to the finish line will win a predetermined amount of tickets. The more players in a race, the higher amount of tickets rewarded. (Optional)

### **Recommended Pricing and Ticket Distribution:**

- Charge \$2.00 to play.
- Recommend to use 2" x 4" Tickets to redeem for prizes for best incremental results.
- Option available to distribute standard size tickets also.





# WATER GUN FUN PIXEL PLAY

# FEC Model Group Game Attendant Free



PIXEL WATER FEC 5 UNIT

POWER REQMT.

(2) 110V - 10 AMP

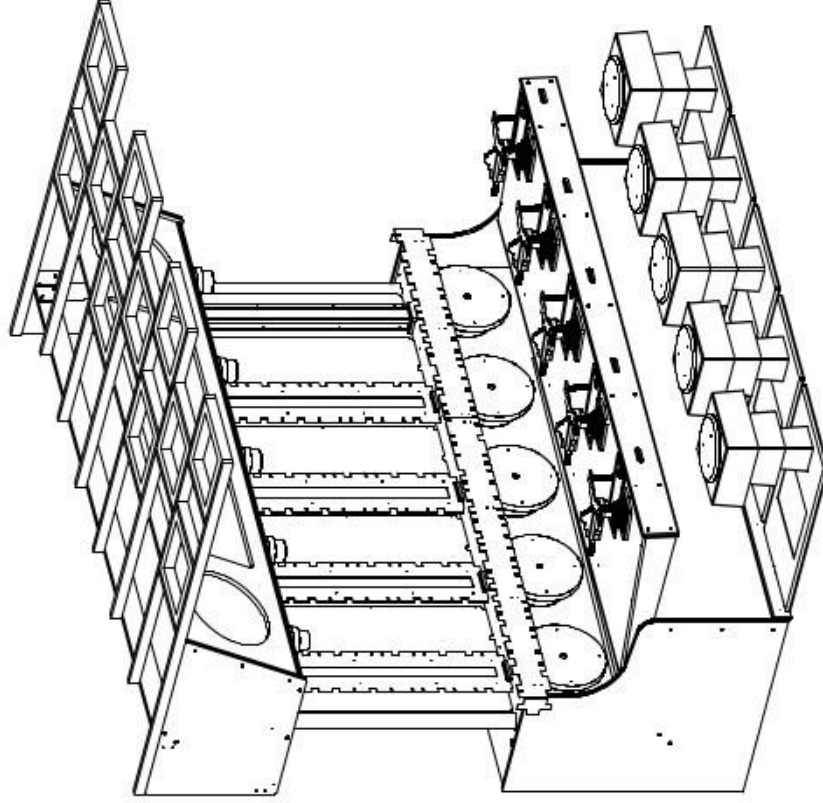
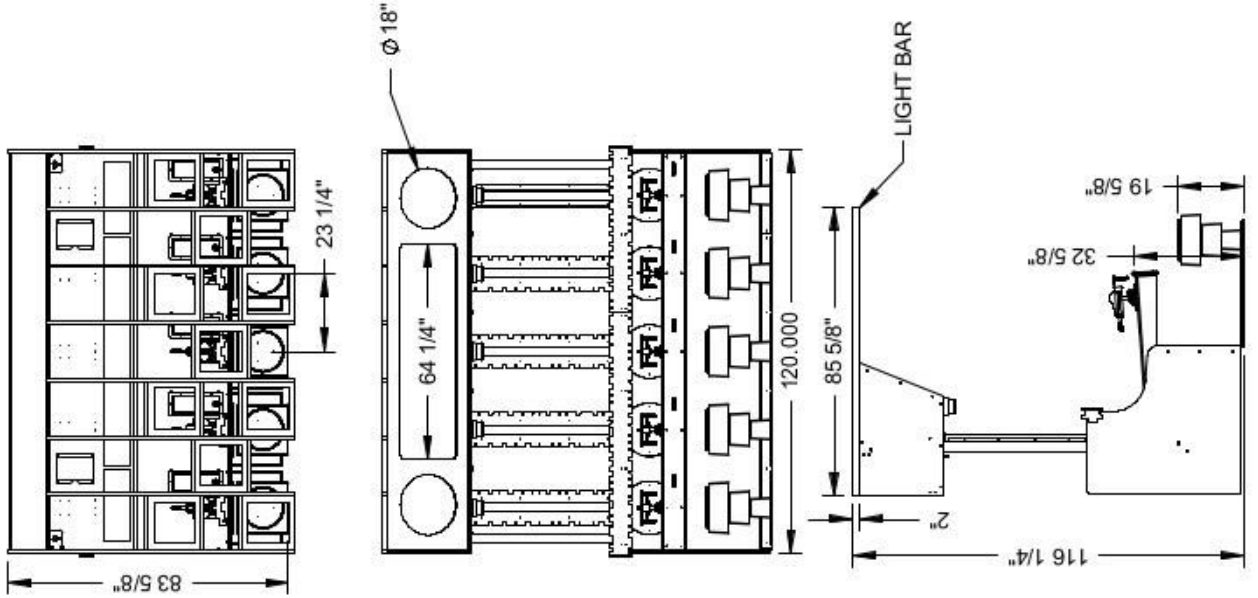

**Bob's Space Racers, Inc.**

427 15th Street  
Daytona Beach, FL 32117  
PH: 386-677-0761  
FAX: 386-677-0794  
Web: <http://www.BobsSpaceRacers.com>  
E-mail: [Sales@BobsSpaceRacers.com](mailto:Sales@BobsSpaceRacers.com)

Serving the amusement industry since 1970



www.bobsspacers.com



## ***FEC Model 4 Player Group Game Attendant Free Standard and Custom Models***

### ***Features:***

- Whac-A-Mole® FEC Model can utilize specialized 2" x 4" redemption tickets or standard 1" x 2" tickets.



- Low maintenance electronics package.
- Secure 48" Prize Display Cabinets standard.
- Available in 4, 5, or 6 player models.

### ***Game Play:***

- Operates without an operator.
- The game is pre-wired to utilize any card swipe system to coin up a game.
- Once a player coins up, the game will begin to count down to start the race.
- Countdown timer resets once another player coins up.
- When countdown timer reaches "0", the race will start.
- Players hit their moles as they pop up and each mole is worth ten points. First player to the score 150 points will win a predetermined amount of tickets. The more players in a race, the higher amount of tickets rewarded. (Optional)

### ***Recommended Pricing and Ticket Distribution:***

- Charge \$2.00 to play.
- Recommend to use 2" x 4" Tickets to redeem for prizes for best incremental results.
- Option available to distribute standard size tickets also.





# FEC Model Group Game Attendant Free



FEC WHAC-A-MOLE

POWER REQMT.	GAME UNITS	'A' DIM. LENGTH	'B' DIM WIDTH	'C' DIM HEIGHT
(1) 110V - 20 AMP	4 UNIT	109 3/4"	30 3/8"	83 1/2"
(1) 110V - 20 AMP	5 UNIT	164 1/4"	30 3/8"	83 1/2"
(1) 110V - 20 AMP	6 UNIT	218 3/4"	30 3/8"	83 1/2"

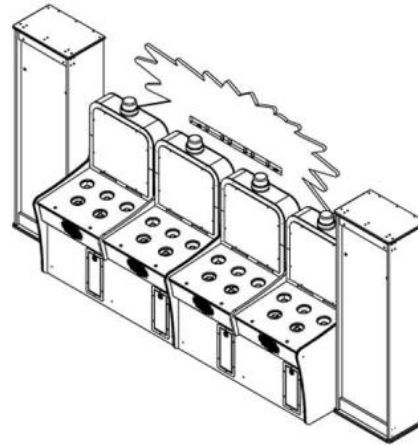
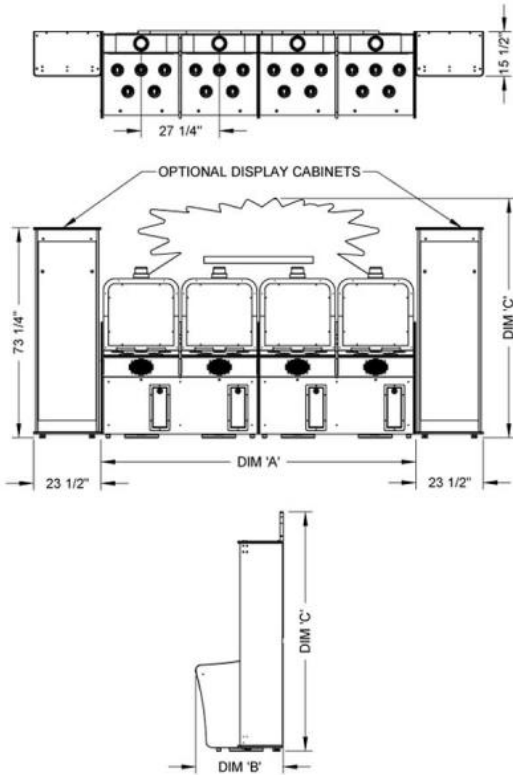

Bob's Space Racers, Inc.

427 15th Street  
Daytona Beach, FL 32117  
PH: 386-677-0761  
FAX: 386-677-0794  
Web: <http://www.BobsSpaceRacers.com>  
E-mail: [Sales@BobsSpaceRacers.com](mailto:Sales@BobsSpaceRacers.com)  
Serving the amusement industry since 1970

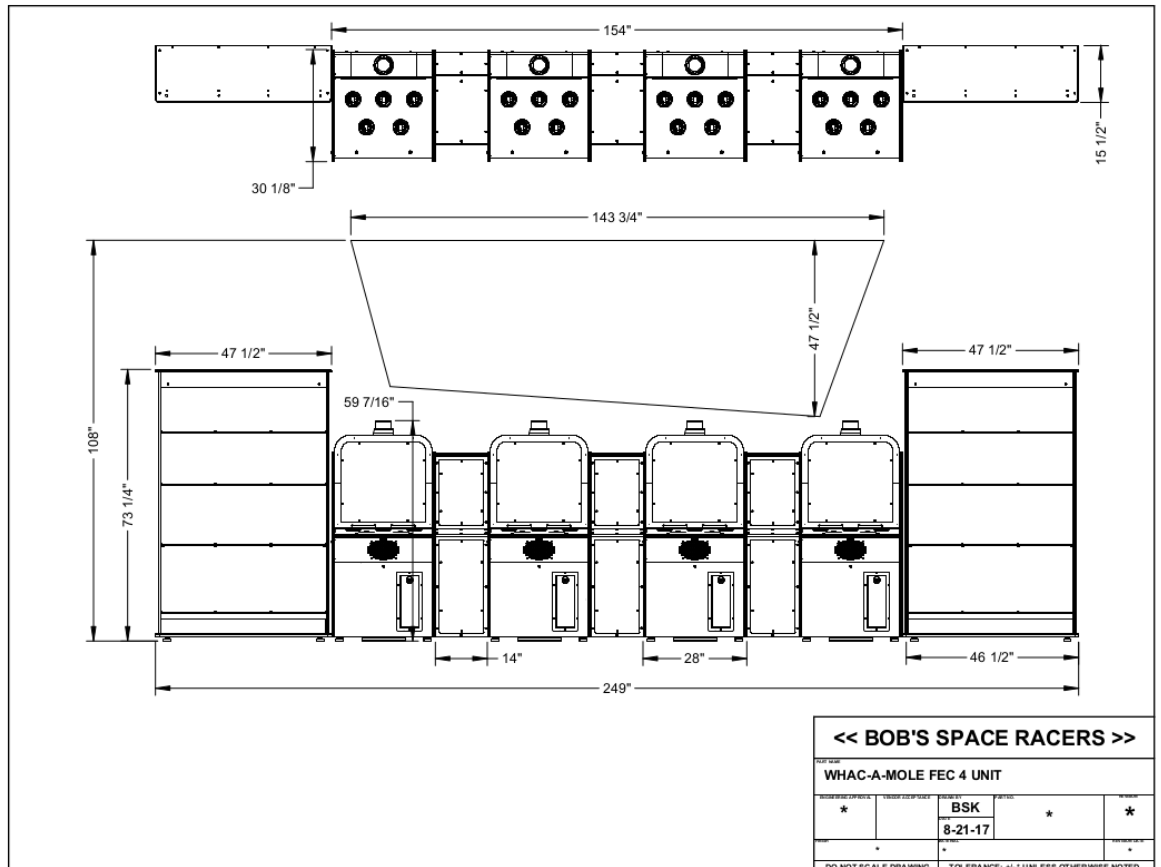

<< BOB'S SPACE RACERS >>			
WHAC-A-MOLE FEC 4 UNIT			
*	BSK	*	*
	8-21-17		
DO NOT SCALE DRAWING TOLERANCE: +/- UNLESS OTHERWISE NOTED			



# WATER GUN FUN

**Water Gun Fun™ FEC Model**  
**5 Player Group Game**  
**Attendant Free**

[www.bobsspacers.com](http://www.bobsspacers.com)

## Features:

- The Water Gun Fun™ FEC Model can utilize specialized 2" x 4" redemption tickets or standard 1" x 2" tickets.



- Secured display shelves.
- Low maintenance water system.



## Game Play:

- Operates without an operator.
- The game is pre-wired to utilize any card swipe system to coin up a game.
- Once a player coins up, the game will begin to count down to start the race.
- Countdown timer resets once another player coins up.
- When countdown timer reaches "0", the race will start.
- Players race their toys to the finish line. First player to the finish line will win a predetermined amount of tickets. The more players in a race, the higher amount of tickets rewarded. (Optional)

## Recommended Pricing and Ticket Distribution:

- Charge \$2.00 to play.
- Recommend to use 2" x 4" Tickets to redeem for prizes for best incremental results.
- Option available to distribute standard size tickets also.



# FEC Model Group Game Attendant Free



FEC WATER GUN FUN

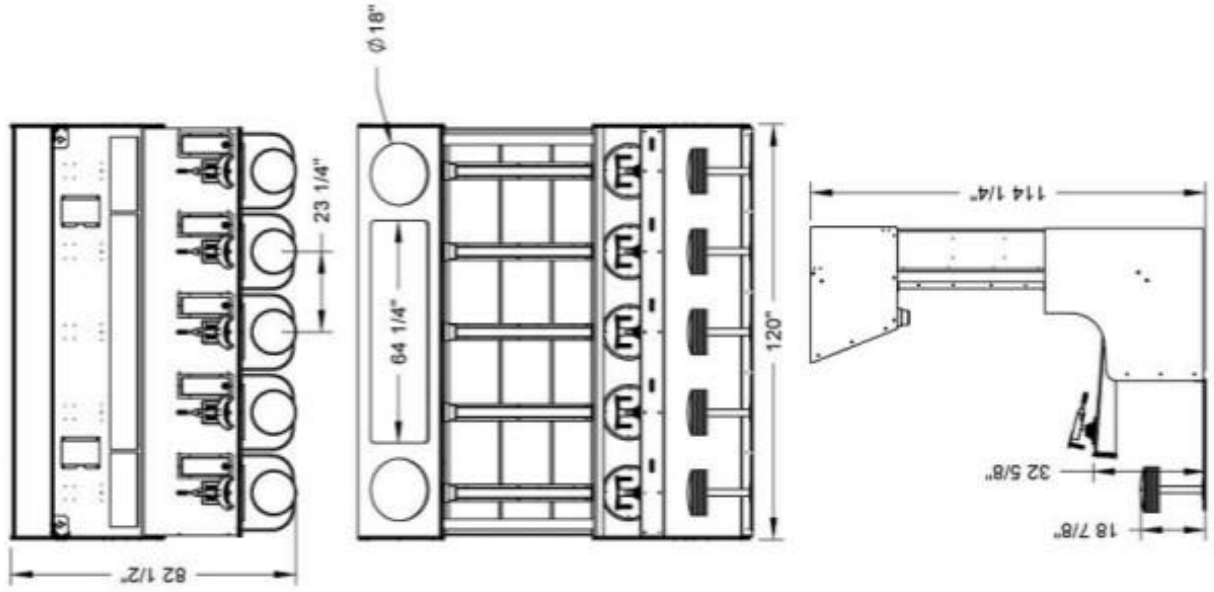

POWER REQMT.

(2) 110V - 10 AMP

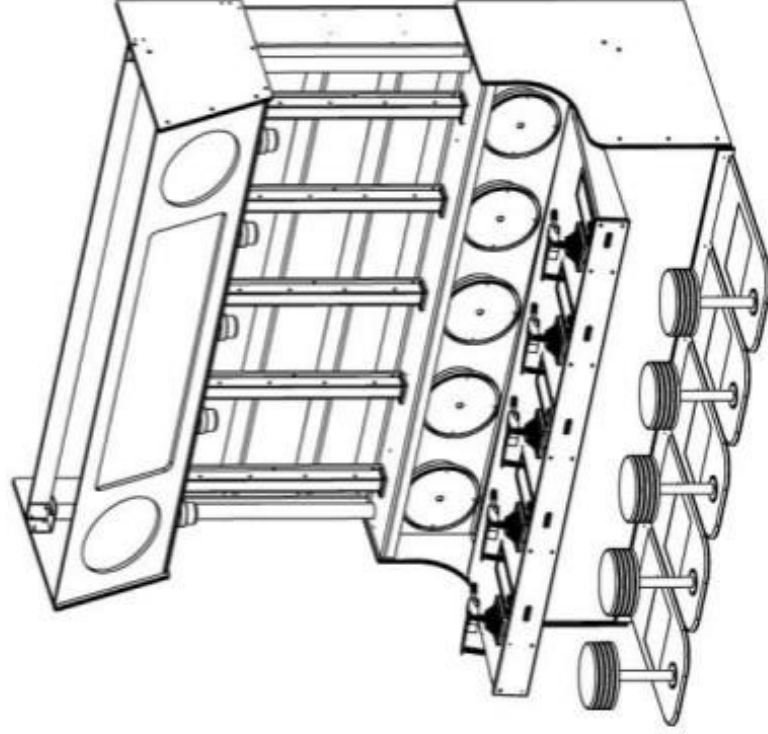

Bob's Space Racers, Inc.

427 15th Street  
Daytona Beach, FL 32117  
PH: 386-677-0761  
FAX: 386-677-0764  
Web: <http://www.BobsSpaceRacers.com>  
E-mail: [Sales@BobsSpaceRacers.com](mailto:Sales@BobsSpaceRacers.com)  
Serving the amusement industry since 1970



www.bobspacers.com

# **Stinky Feet™ FEC Model**

## **4 Player Group Game**

### **Attendant Free**

#### **Features:**

- Water Gun Fun Pixel Play FEC Model can utilize specialized 2" x 4" redemption tickets or standard 1" x 2" tickets.



- Low maintenance water system and electronics.
- Secure 48" Prize Display Cabinets standard.

#### **Game Play:**

- Operates without an operator.
- The game is pre-wired to utilize any card swipe system to coin up a game.
- Once a player coins up, the game will begin to count down to start the race.
- Countdown timer resets once another player coins up.
- When countdown timer reaches "0", the race will start.
- Players race their toys to the finish line. First player to the finish line will win a predetermined amount of tickets. The more players in a race, the higher amount of tickets rewarded. (Optional)

#### **Recommended Pricing and Ticket Distribution:**

- Charge \$2.00 to play.
- Recommend to use 2" x 4" Tickets to redeem for prizes for best incremental results.
- Option available to distribute standard size tickets also.



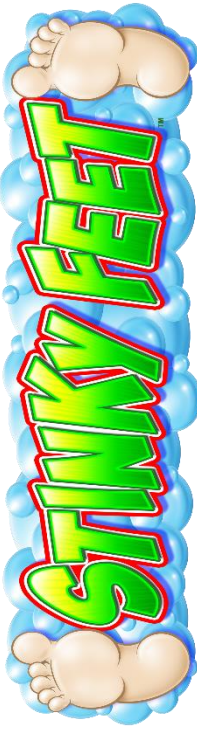

# FEC Model Group Game Attendant Free



POWER REQMT.	GAME SIZE	'A' DIM. LENGTH	'B' DIM. WIDTH	'C' DIM. HEIGHT
(1) 110V - 20 AMP	4 UNIT	109 1/2"	120 1/2"	97 1/2"
(1) 110V - 20 AMP	5 UNIT	136 1/2"	120 1/2"	97 1/2"
(1) 110V - 20 AMP	6 UNIT	163 1/2"	120 1/2"	97 1/2"

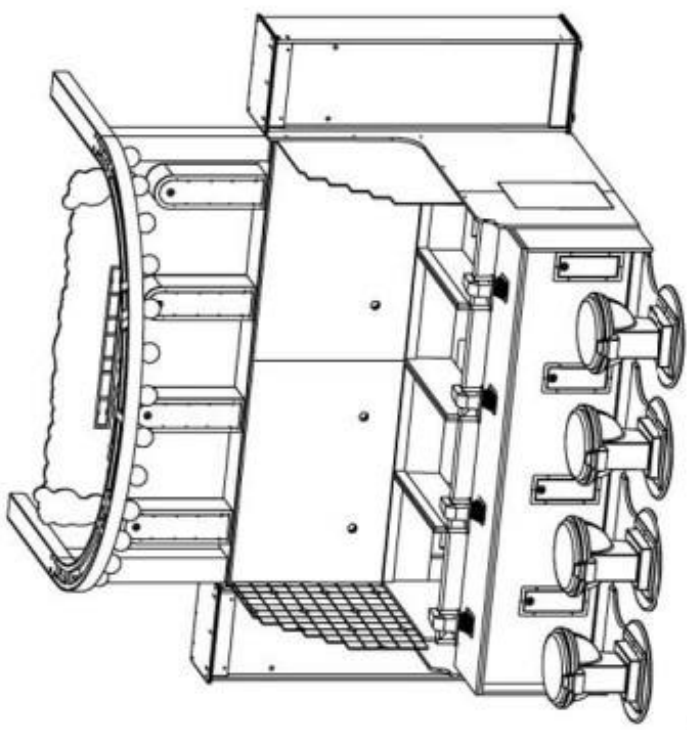
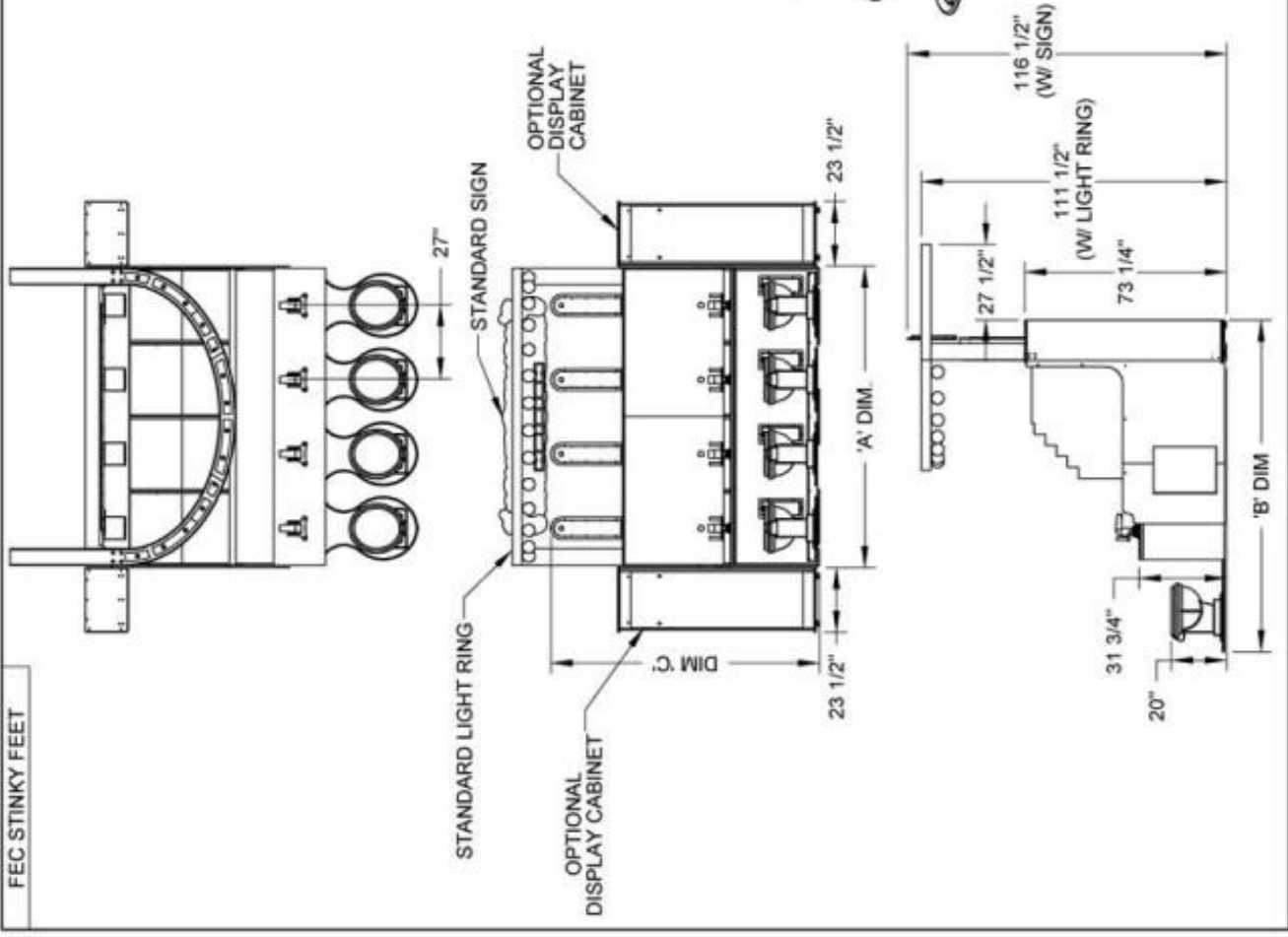

**Bob's Space Racers, Inc.**  
 427 15th Street  
 Daytona Beach, FL 32117  
 PH: 386-677-0761  
 FAX: 386-677-0794  
 Web: <http://www.BobsSpaceRacers.com>  
 E-mail: [Sales@BobsSpaceRacers.com](mailto:Sales@BobsSpaceRacers.com)  
 Serving the amusement industry since 1970



www.bobsspacers.com

# JUMPIN' MONKEYS™

## ***FEC Model 5 Player Group Game Attendant Free***

### ***Features:***

- Jumpin' Monkeys™ FEC Model can utilize specialized 2" x 4" redemption tickets or standard 1" x 2" tickets.



- Low maintenance electronics package.
- Secure 48" Prize Display Cabinets standard.
- Optional: Prize Barrels (Seen at top of picture to right)
- Available in 4, 5, or 6 player models.



Contact our Sales Team  
at [sales@bsrgames.com](mailto:sales@bsrgames.com) or  
386-677-0761  
for more information.

### ***Game Play:***

- Operates without an operator.
- The game is pre-wired to utilize any card swipe system to coin up a game.
- Once a player coins up, the game will begin to count down to start the race.
- Countdown timer resets once another player coins up.
- When countdown timer reaches "0", the race will start.
- Players race their toys to the finish line. First player to the finish line will win a predetermined amount of tickets. The more players in a race, the higher amount of tickets rewarded. (Optional)

### ***Recommended Pricing and Ticket Distribution:***

- Charge \$2.00 to play.
- Recommend to use 2" x 4" Tickets to redeem for prizes for best incremental results.
- Option available to distribute standard size tickets also.



# JUMPIN' MONKEYS

## FEC Model Group Game Attendant Free



FEC JUMPIN' MONKEYS

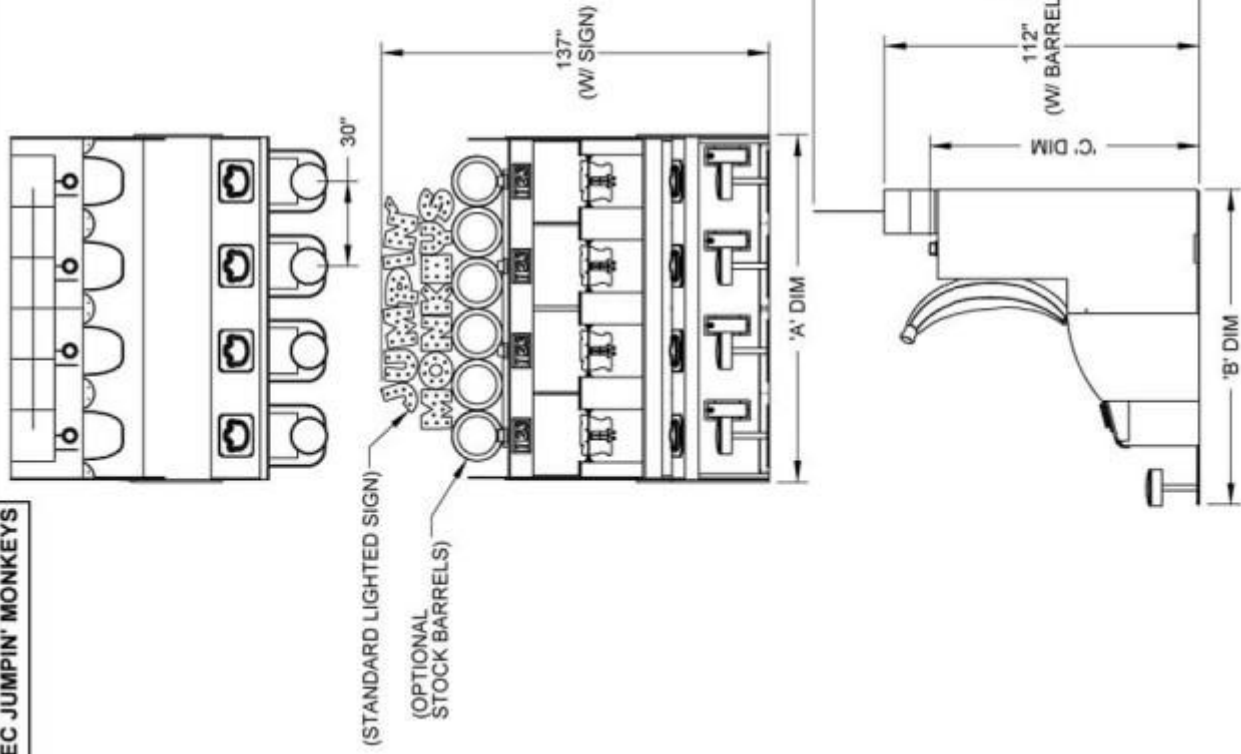

POWER REQMT.	GAME SIZE	'A' DIM. LENGTH	'B' DIM. LENGTH	'C' DIM. LENGTH
(1) 110V - 10 AMP	4 UNIT	123"	111 1/2"	96 3/16"
(1) 110V - 10 AMP	5 UNIT	153"	111 1/2"	96 3/16"
(1) 110V - 10 AMP	6 UNIT	183"	111 1/2"	96 3/16"

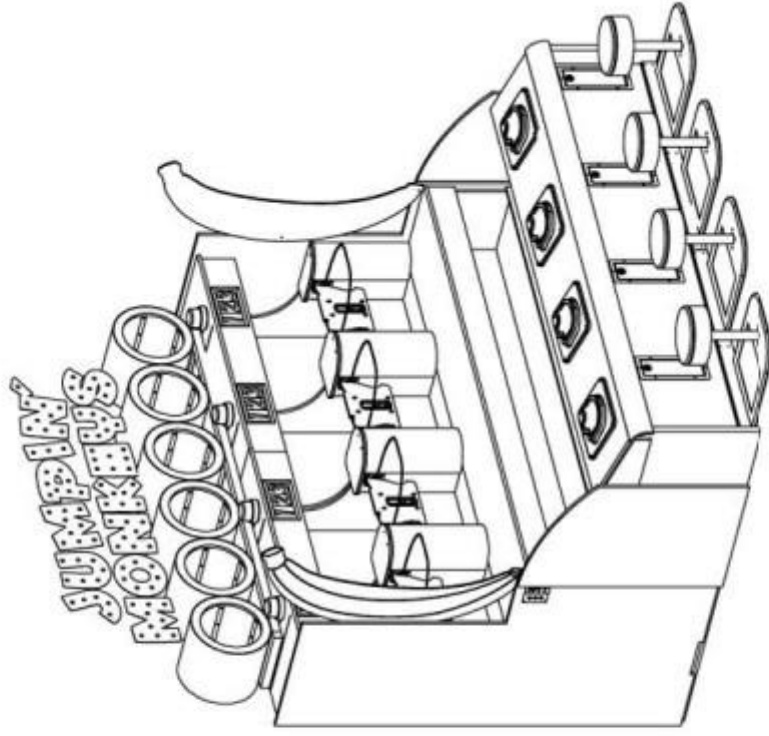

**Bob's Space Racers, Inc.**

427 15th Street  
 Daytona Beach, FL 32117  
 PH: 386-677-0781  
 FAX: 386-677-0794  
 Web: <http://www.BobsSpaceRacers.com>  
 E-mail: [Sales@BobsSpaceRacers.com](mailto:Sales@BobsSpaceRacers.com)  
 Serving the amusement industry since 1970



# Bob's Space Racers

427 Whac-A-Mole Way

Holy Hill, FL 32117

Phone: 386-677-0761

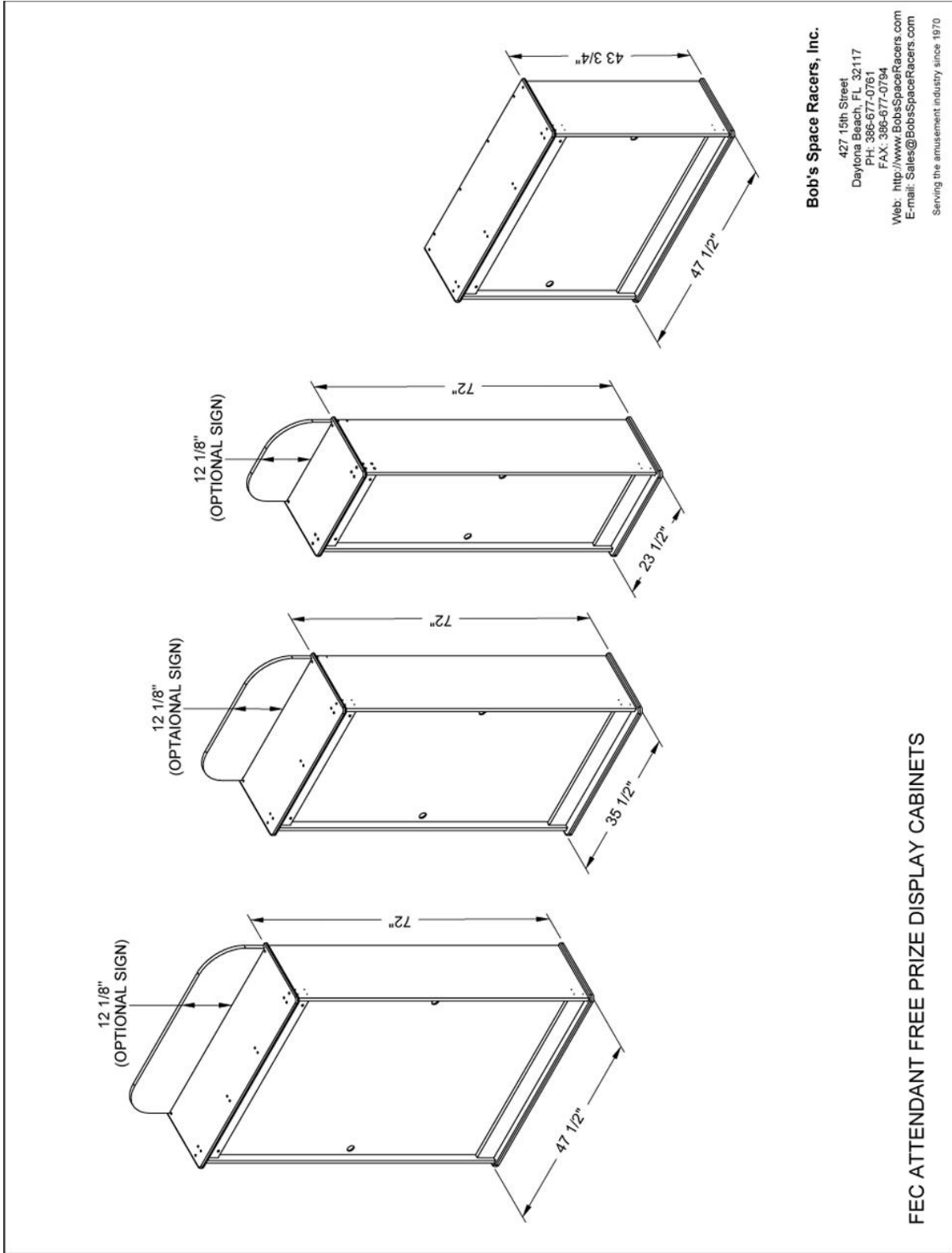

### Bob's Space Racers, Inc.

427 15th Street  
 Daytona Beach, FL 32117  
 PH: 386-677-0761  
 FAX: 386-677-0794  
 Web: <http://www.BobsSpaceRacers.com>  
 E-mail: [Sales@BobsSpaceRacers.com](mailto:Sales@BobsSpaceRacers.com)  
 Serving the amusement industry since 1970

FEC ATTENDANT FREE PRIZE DISPLAY CABINETS

**[WWW.BOBSSPACERACERS.COM](http://WWW.BOBSSPACERACERS.COM)**

Call or email our sales team at:  
 Phone: 386-677-0761  
 Email: [sales@bobsspacracers.com](mailto:sales@bobsspacracers.com)



**Bob's Space Racers**  
 427 Whac-A-Mole Way  
 Holy Hill, FL 32117  
 Phone: 386-677-0761

# FEC's STANDARD Sign Package

8" H x 18" W

8" H x 18" W



**1 each per game**



**1 each per game**

3.3" H x 9.5" W



**X 3**

**( 18 Ticket signs total )**

**[WWW.BOBSSPACERACERS.COM](http://WWW.BOBSSPACERACERS.COM)**

Call or email our sales team at:  
 Phone: 386-677-0761  
 Email: [sales@bobsspaceracers.com](mailto:sales@bobsspaceracers.com)



**Bob's Space Racers**

427 Whac-A-Mole Way

Holy Hill, FL 32117

Phone: 386-677-0761

# FEC (Attendant Free) Group Game Operational Information

***WWW.BOBSSPACERACERS.COM***

Call or email our sales team at:

Phone: 386-677-0761

Email: [sales@bobsspacracers.com](mailto:sales@bobsspacracers.com)



## **Bob's Space Racers**

427 Whac-A-Mole Way

Holy Hill, FL 32117

Phone: 386-677-0761

# OPERATIONAL SET-UP SHEET:

**Note: The following Operational Set-Up Sheet refers to SETTING UP THE STOCK DISPLAY and GAME SIGNAGE, and TIPS FOR DISTRIBUTING PRIZES FROM REDEMPTION COUNTER for all Bob's Space Racers FEC games.**

## SETTING UP THE STOCK DISPLAY (A.K.A. - FLASH) AND GAME SIGNAGE

1. How to display prizes on any Bob's Space Racers FEC game:
  - a. Based on the price of the game you charge the guest to play and the cost of plush you distribute, will determine what game signage to use for the game. Note, it is not recommended to have more than 4 prize tiers.
  - b. Display the largest, most popular prizes at eye level or higher.
    - i. Ensure all plush is facing forward
    - ii. Avoid gaps or holes between plush to create a full appearance
    - iii. Show the full size of the prize if possible
    - iv. Try to maintain straight lines on all prize displays
    - v. Ensure the majority of your display consists of the largest, most popular prizes
    - vi. Do not mix the different prize level prizes in your display to ensure there is a clear distinction between the different prize levels to avoid guest confusion.
  - c. Display the smallest first win prizes on the lowest level of your plush display.
    - i. Ensure all plush is facing forward
    - ii. Avoid gaps or holes between plush to create a full appearance
    - iii. Show the full size of the prize if possible
    - iv. Try to maintain straight lines on all prize displays
    - v. Do not mix the different prize level prizes in your display to ensure there is a clear distinction between the different prize levels to avoid guest confusion.

***WWW.BOBSSPACERACERS.COM***

Call or email our sales team at:

Phone: 386-677-0761

Email: [sales@bobsspacracers.com](mailto:sales@bobsspacracers.com)



## **Bob's Space Racers**

427 Whac-A-Mole Way

Holy Hill, FL 32117

Phone: 386-677-0761

- a. Add ***Ticket Signage (1,2,3,4,6, or 8 Tickets)*** either in front of or attached, to the correlating prize level that the sign represents
  - i. Ensure the prize level signage is placed where it is most visible to guests
  - ii. If your display has, for example: three shelves or three rows of display, ensure each shelf or row is labeled with the ***1,2,3,4,6, or 8 Ticket(s)*** signs as it correlates to the prizes the game distributes to avoid confusion from guests

### TIPS FOR DISTRIBUTING PRIZES FROM REDEMPTION COUNTER

1. Keep an adequate amount of prizes for every prize level behind the redemption counter for prize giveaways.
  - a. It is recommended to neatly display some of these prizes behind the redemption counter with a sign stating that the prizes can be won at your FEC game.
2. Count all tickets turned in from the FEC game on a daily basis
  - a. When performing an inventory on prizes distributed from the FEC game, they should balance with the same amount of tickets returned from guests

***WWW.BOBSPACERACERS.COM***

Call or email our sales team at:

Phone: 386-677-0761

Email: [sales@bobspaceracers.com](mailto:sales@bobspaceracers.com)



## Bob's Space Racers

427 Whac-A-Mole Way

Holy Hill, FL 32117

Phone: 386-677-0761

### Factoring Game Pricing, Prize Pricing, and Cost Of Sales (COS) for your FEC Race Game:

Example 1	Revenue Generated Per Game	COS for 1st Win	COS for 2nd Win
2 Players	\$ 4.00	30%	30%
3 Players	\$ 6.00	20%	20%
4 Players	\$ 8.00	15%	15%
5 Players	\$ 10.00	12%	12%
6 Players	\$ 12.00	10%	10%

Cost per player per game \$ 2.00

Cost of 1st Win Prize \$ 1.20

Cost of 2nd Win Prize \$ 2.40

Example 2	Revenue Generated Per Game	COS for 1st Win	COS for 2nd Win
2 Players	\$ 6.00	29%	29%
3 Players	\$ 9.00	19%	19%
4 Players	\$ 12.00	15%	15%
5 Players	\$ 15.00	12%	12%
6 Players	\$ 18.00	10%	10%

Cost per player per game \$ 3.00

Cost of 1st Win Prize \$ 1.75

Cost of 2nd Win Prize \$ 3.50

### How to factor what price to use, cost of plush to use, and minimum and maximum COS for your game:

Note: Change the values in the yellow boxes to factor generated revenue and COS below.

How much will you charge per player, per race?

How many player positions are on your game?

What is the cost of the 1st Win prize (one ticket) you would like to use for your game?

What is the cost of the 2nd Win prize (two tickets) you would like to use for your game?

\$	2.00
	6
\$	1.20
\$	2.40

	Revenue Generated per Race	1st Win Prize COS	2nd Win Prize COS
Minimum Cost Of Sales:	6 Players \$ 12.00	10%	10%
Maximum Cost Of Sales:	2 Players \$ 4.00	30%	30%

NOTE: ACTUAL EXCEL SPREADSHEET AVAILABLE UPON REQUEST.



**Bob's Space Racers**

427 Whac-A-Mole Way

Holy Hill, FL 32117

Phone: 386-677-0761

# **FEC (Attendant Free) Group Game Maintenance Information**

***WWW.BOBSSPACERACERS.COM***

Call or email our sales team at:

Phone: 386-677-0761

Email: [sales@bobsspacracers.com](mailto:sales@bobsspacracers.com)





**Bob's Space Racers**  
427 Whac-A-Mole Way  
Holy Hill, FL 32117  
Phone: 386-677-0761



PIXEL PLAY™ FEC, WATER BLAST™ FEC, STINKY FEET™ FEC,  
AND WATER GUN FUN™ FEC FROM BOB'S SPACE RACERS, INC.

## MAINTENANCE SCHEDULE

### DAILY MAINTENANCE:

1. Check water level in tank and refill as needed.
2. Test each unit for proper operation:
  - a. Each unit activates properly
  - b. Each unit shoots a solid stream of water
  - c. Each unit wins
3. Check tickets

### WEEKLY MAINTENANCE:

1. Drain water from tank and replace with clean water
2. Clean water filter
3. Check all lights and replace as needed

***Tech Tip:*** Many customers use ice from filtered ice machine for better water quality.

### MONTHLY MAINTENANCE:

1. Clean game
  - a. Clean hard water stains and lime deposits from tankback and counter
  - b. Wipe down all game surfaces

NOTE: IT IS RECOMMENDED TO VISIT OUR WEBSITE AT [WWW.BOBSSPACERACERS.COM](http://WWW.BOBSSPACERACERS.COM) FOR RECOMMENDATIONS ON PROPER WATER TREATMENT TIPS AS NEEDED.

***WWW.BOBSSPACERACERS.COM***

Call or email our sales team at:  
Phone: 386-677-0761  
Email: [sales@bobsspaceracers.com](mailto:sales@bobsspaceracers.com)



**Bob's Space Racers**  
427 Whac-A-Mole Way  
Holy Hill, FL 32117  
Phone: 386-677-0761



## JUMPIN' MONKEYS™ FEC FROM BOB'S SPACE RACERS, INC.

### MAINTENANCE SCHEDULE

#### DAILY MAINTENANCE:

1. Test each unit for proper operation:
  - a. Each unit activates properly
  - b. Each units hoop rotates properly
  - c. Each unit lose sensor activates properly
  - d. Each unit wins
2. Check for proper hoop calibration:
  - a. Look to see if all hoops on the game are lined up the same.  
Recalibrate as needed.
3. Check tickets.

#### WEEKLY MAINTENANCE:

1. Calibrate the hoops
2. Check all game lighting. Repair/Replace as needed.

#### MONTHLY MAINTENANCE:

1. Clean solenoid shafts for each unit.
2. Check that everything is tight and nothing has loosened due to vibration.

***WWW.BOBSSPACERACERS.COM***

Call or email our sales team at:  
Phone: 386-677-0761  
Email: [sales@bobsspacracers.com](mailto:sales@bobsspacracers.com)



**Bob's Space Racers**  
427 Whac-A-Mole Way  
Holy Hill, FL 32117  
Phone: 386-677-0761



# WHAC-A-MOLE™ FEC FROM BOB'S SPACE RACERS, INC.

## MAINTENANCE SCHEDULE

### DAILY MAINTENANCE:

1. Test each unit for proper operation:
  - a. Each unit activates properly
  - b. Each units mole heads pop up correctly
  - c. Each units mole head scores properly
  - d. Each unit wins
2. Check tickets

### WEEKLY MAINTENANCE:

1. Check for sticking or slow moving mole heads
2. Check all mole heads rubber bushing for wear and repair/replace as needed
3. Check hammer conditions; replace as needed

### MONTHLY MAINTENANCE:

1. Remove play tops:
  - a. Clean mole box assemblies as needed
  - b. Remove mole heads and clean shafts and coils
  - c. Check that everything is tight and that no parts have become loose due to vibration

***WWW.BOBSPACERACERS.COM***

Call or email our sales team at:  
Phone: 386-677-0761  
Email: [sales@bobsspaceracers.com](mailto:sales@bobsspaceracers.com)