

Game Installation Manual

FEC Roll-A-Ball Game



Bob's Space Racers
427 Whac-A-Mole Way
Holly Hill, FL 32117
Phone: 386-677-0761

BOB'S SPACE RACERS
PROTOTYPE FEC RAB 6UNIT

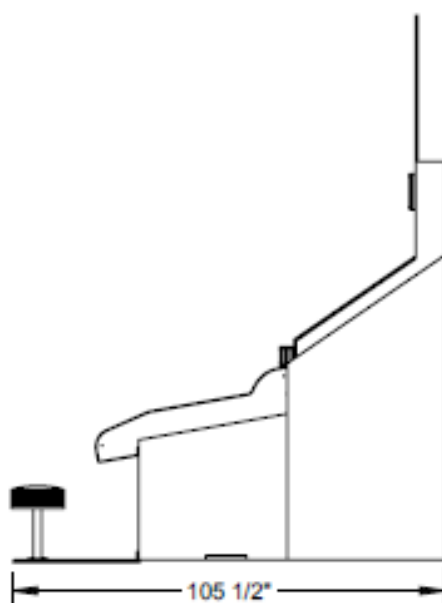
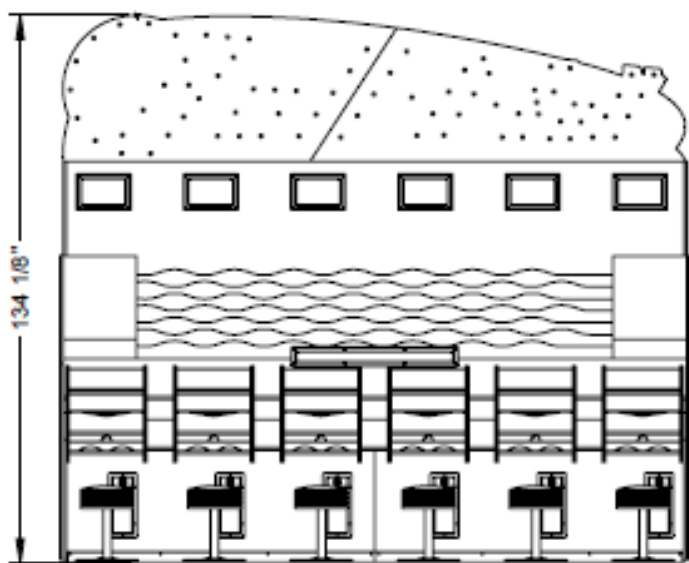
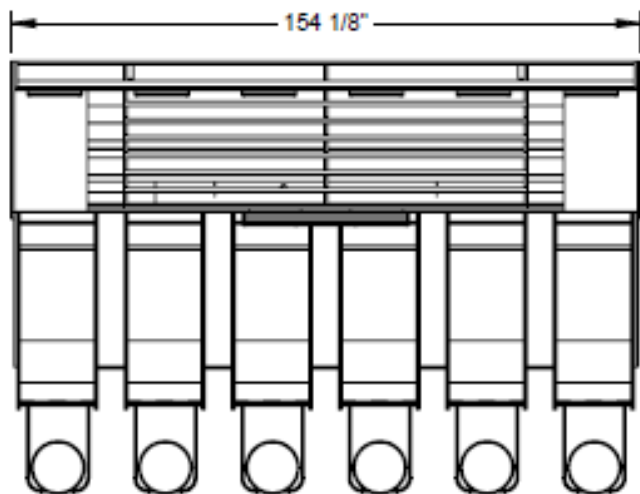

BOB'S SPACE RACERS

ROLL A BALL 6 UNIT FEC

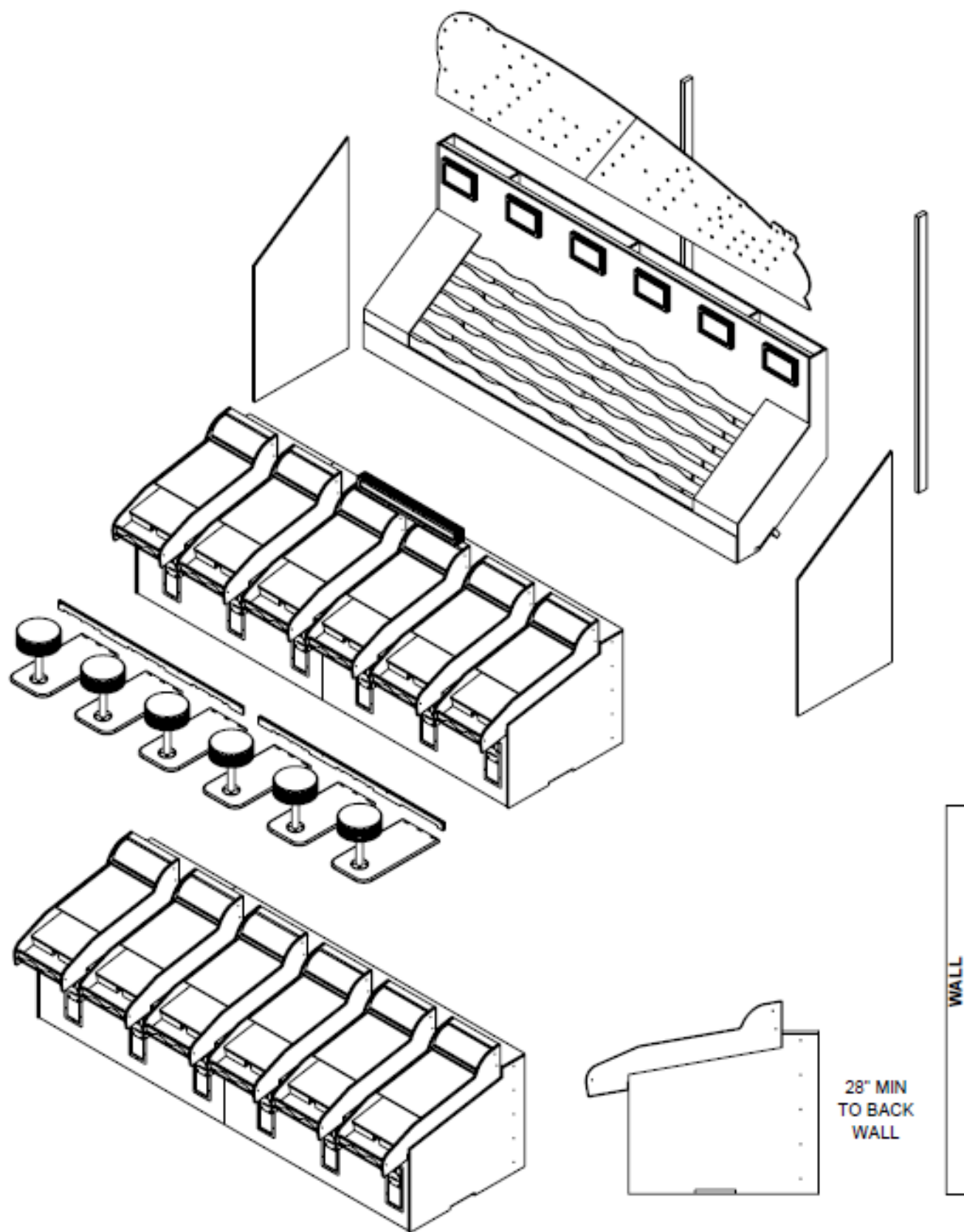

BOB'S SPACE RACERS

ROLL A BALL 6 UNIT FEC

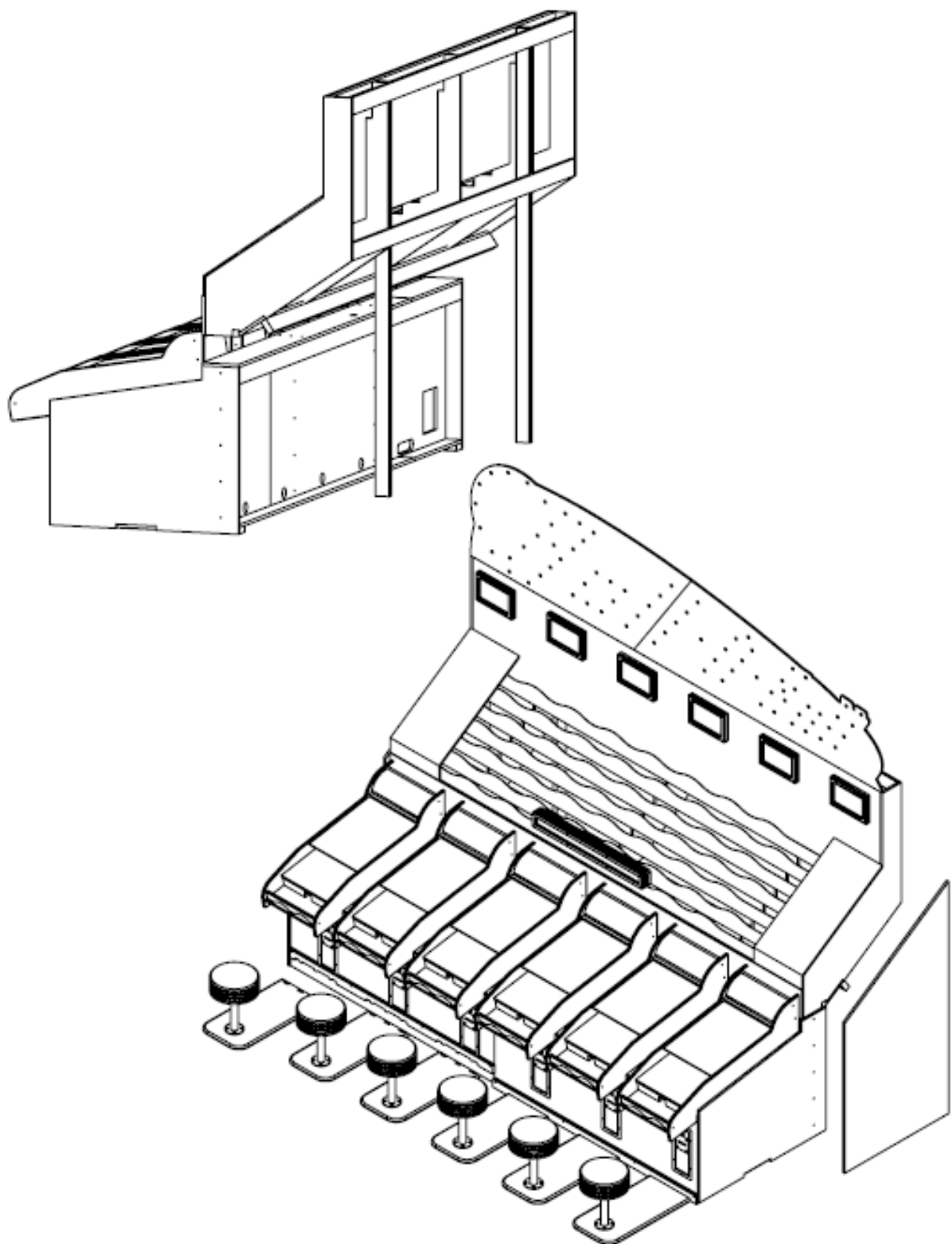

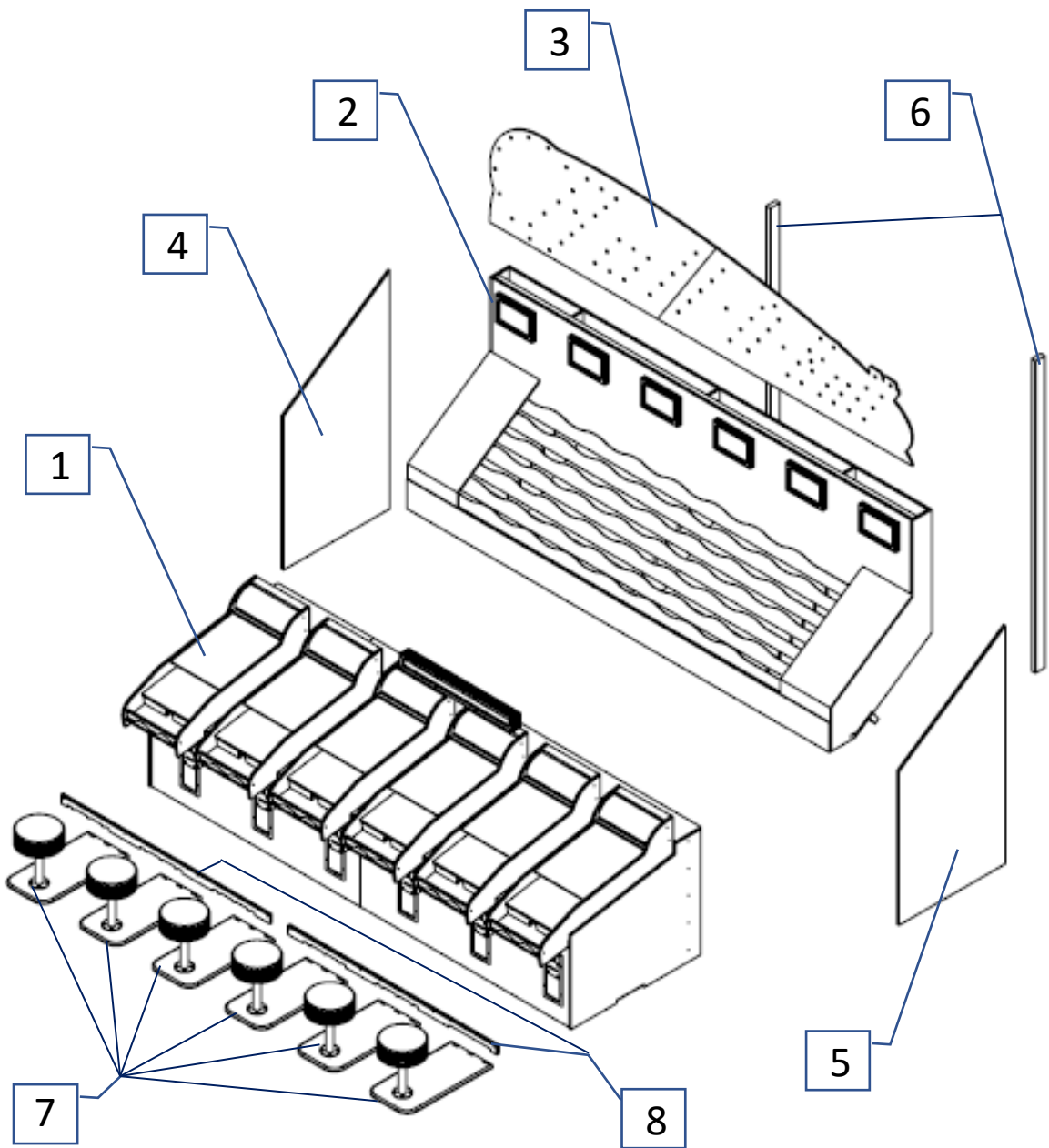

- 1. Playfield Cabinet
- 2. Ramp
- 3. Sign
- 4. Side Wing (Left)
- 5. Side Wing (Right)

- 6. Ramp Support Legs
- 7. Seats and Bases
- 8. Locking Toe-Kicks

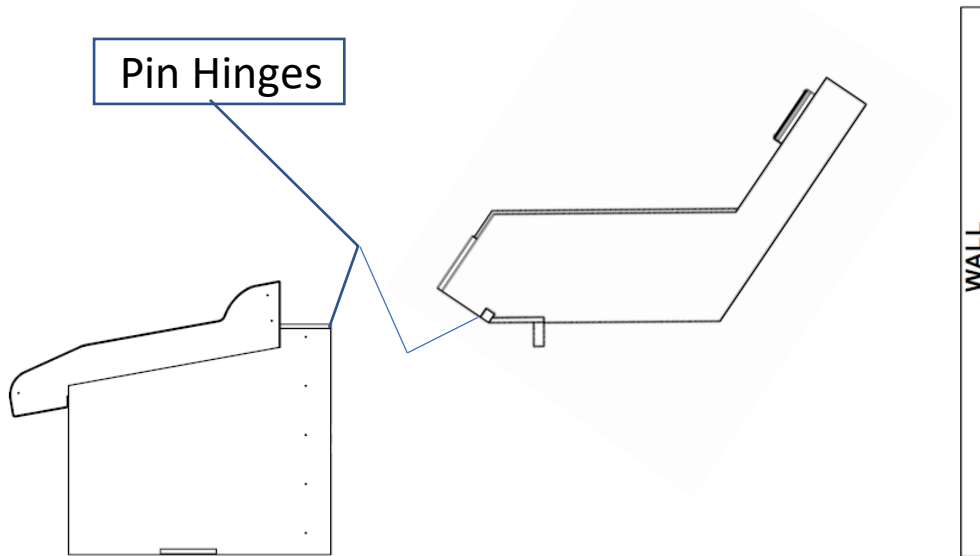

Recommended Labor: 6 People / 6 Hours

Tools Needed For Install:

- Cordless Drill
- #8 Square tip Bit
- Two Driver Sockets and Wrenches of the following Sizes: 5/16", 7/16", 1/2", 9/16"
- Four 4-Wheel furniture dollies
- Hammer
- Prybar
- Two 10' Ladders
- Carpet Sliders (provided / use only if applicable)

Step 1:

- Find Hardware Box – the hardware box will contain all the hardware needed for the installation. The hardware box will be located on the pallet with the Playfield Cabinet.

Step 2:

- Place the Playfield Cabinet directly in front of the wall where the game will be located. Allow for plenty of space between the Playfield Cabinet and back wall to allow for the Ramp section to be hand carried (in table topped fashion) behind the Playfield Cabinet.

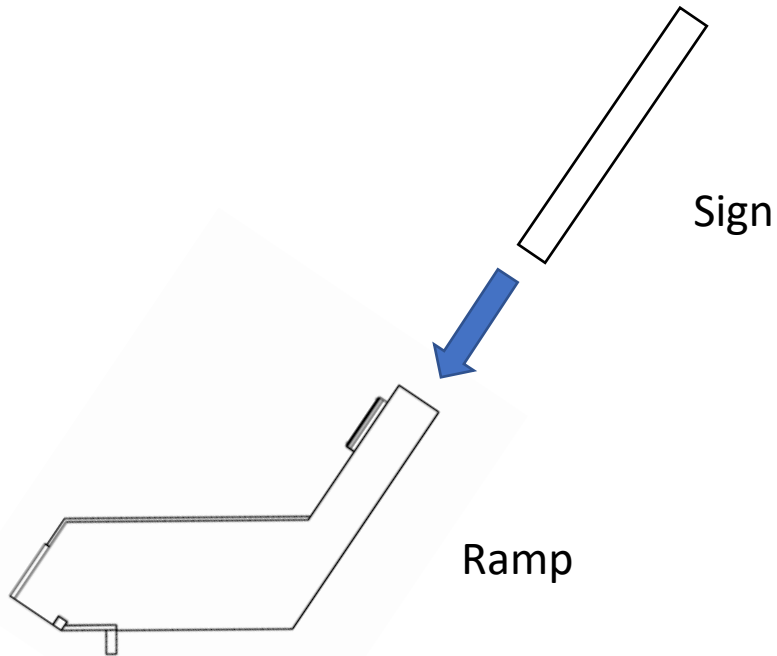

Step 3: Installing the sign

- There are two options for installing the sign: 1) Install the sign when the ramp is upright and attached to the Playfield Cabinet, or 2) (Recommended) Attach the sign while the ramp is not attached.
- To install the sign, there will be three metal brackets that attach to the back of the game. The sign has three legs that will slide into these brackets to complete installation of the sign.

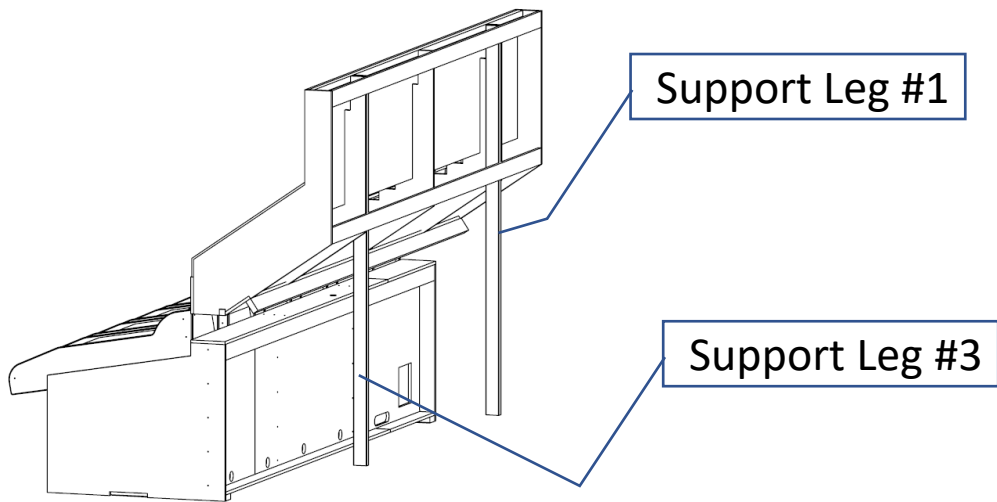

Step 4:

- Have Ramp Support Legs, Hardware and hinge pins (see note below concerning pin hinges) at the ready and hand carry the Ramp section behind the Playfield Cabinet (positioned as pictured above) and attach the Ramp section to the Playfield Cabinet utilizing the pin-hinges:
 - The pins for the hinges should be taped in place on one half of the hinges located on the back of the Playfield Cabinet. Remove tape and pull pins before lining up both pin hinges. One half of the hinge is located at base of the Ramp section and the other half of the hinge is located at the top-back of the Playfield. Line up the hinges and insert the pins into the hinges.

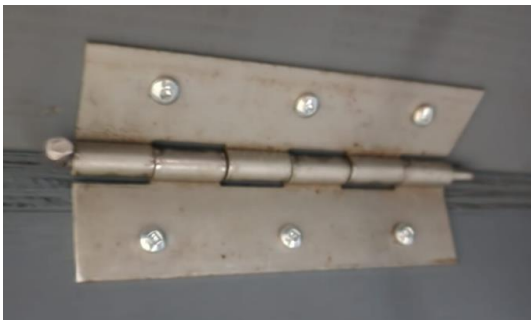

Pin Hinge (Assembled)

Step 5:

- Once the hinges are pinned, raise the back of the Ramp up and attached the Ramp Support Legs. The Support Legs and Ramp have labeled numbers on both (#1 and #3). Using two of the provided hex bolts and washers, the #1 Support Leg is attached to the Ramp next to the #1 label and use two more hex bolts where the #3 Support Leg is attached to the Ramp next to the #3 label.



Ramp Support Legs (Assembled)

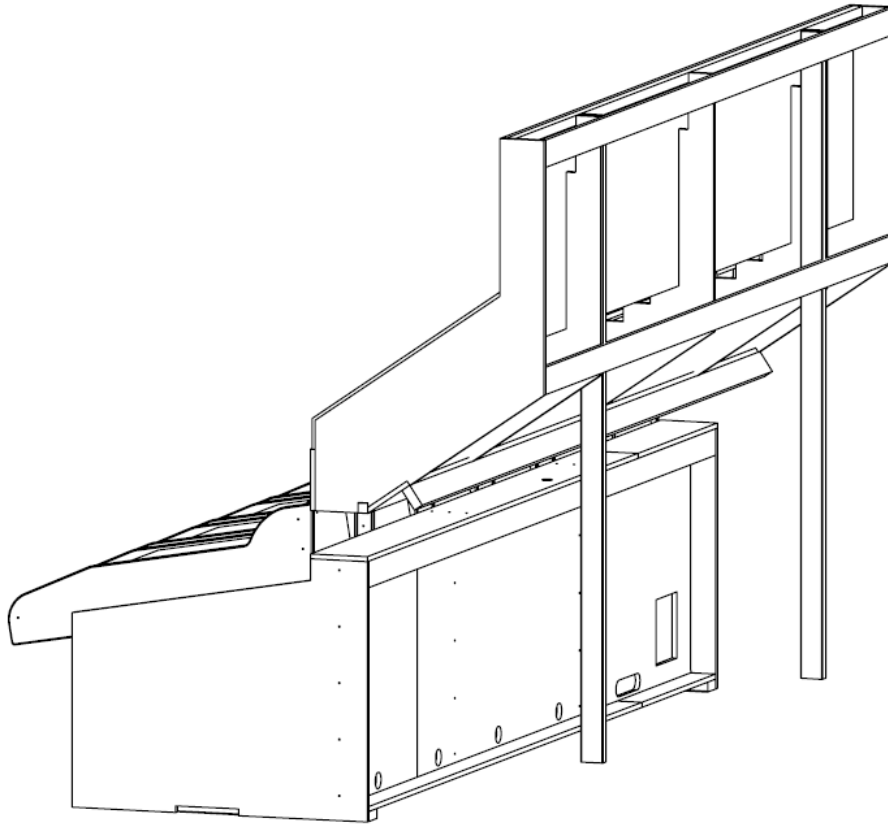

Step 6:

- Once Support Legs are secured, add hex bolts at base of Ramp to further secure the Ramp to the Playfield Cabinet. There will be four hex bolts in total.



Hex Bolts at base of Ramp (Assembled)

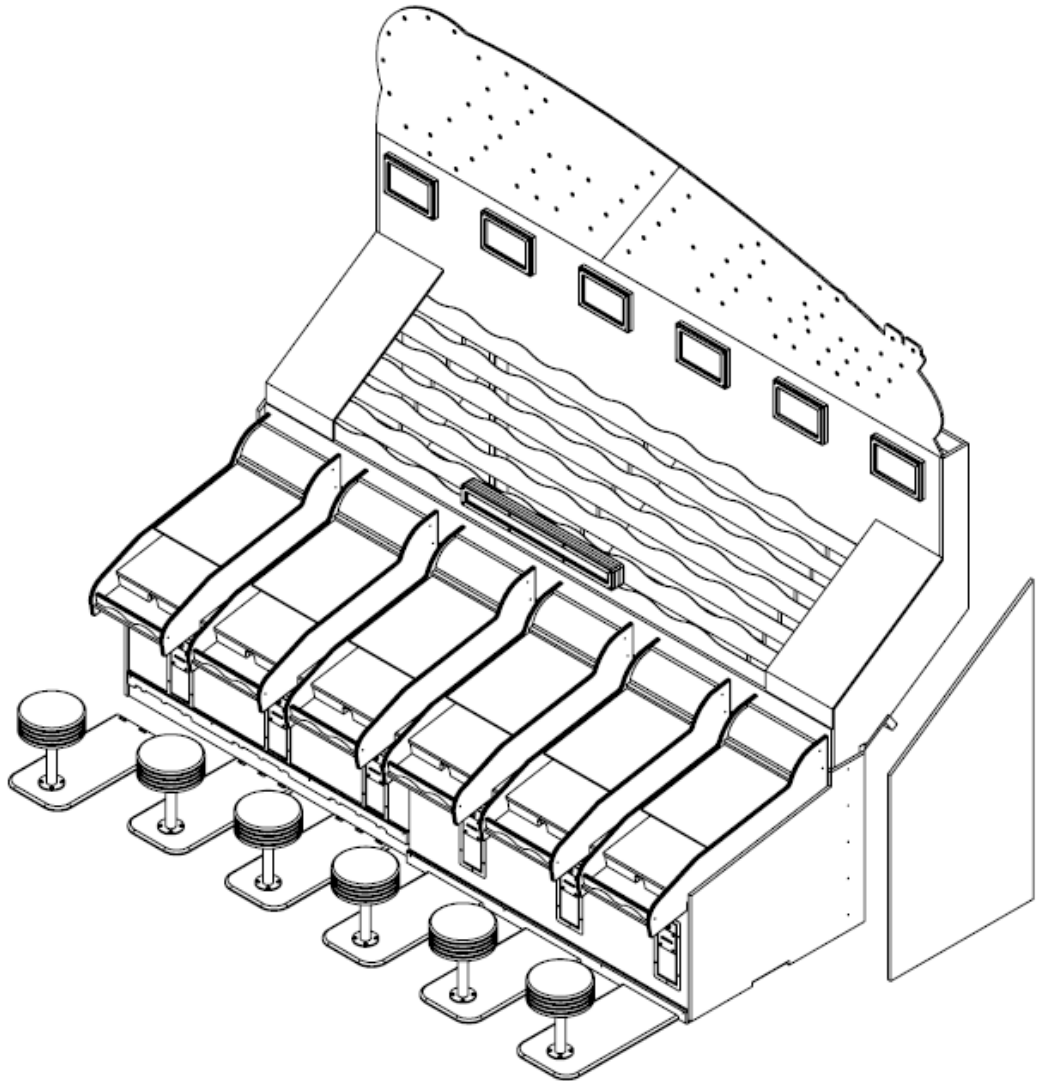

Step 7:

- Attach Side Panels on both sides of the game using provided square tip (Scrulox) screws.
- It is recommended to keep one side off until after all connections are made.

Step 8:

- If the game is on carpet, use a prybar to slightly lift corners of game and place carpet sliders under the four corners of the game and under the Ramp Support Legs. Carpet sliders are not needed if the game is placed on a hard surface like tile.
- Slowly push the entire game back against the wall.
 - **IMPORTANT!!!!** – When pushing the game back, it is very important that pressure is kept off the Ramp Support Legs. It is recommended that two people slightly lift the Ramp when the game is being pushed back to keep the Support Legs from binding while being pushed back into location.

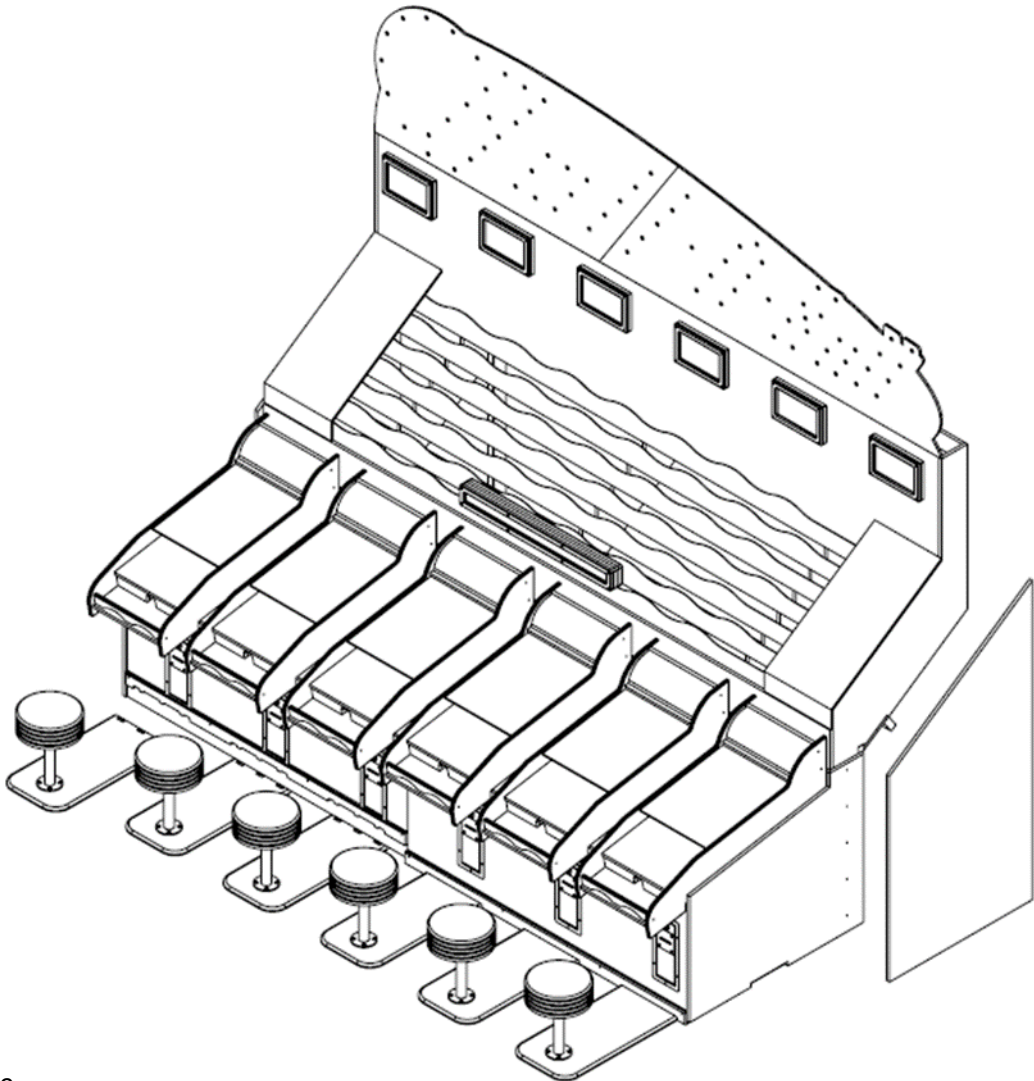

Step 9:

- Attach the seats to the front of the Playfield Cabinet using Scrulox screws (provided) and Locking Toe-Kicks. The seat on the far right (#6 Position) will not lock in place and is intended to be removable for handicap access.

Step 10:

- Attach Bose Speakers to both sides of game.

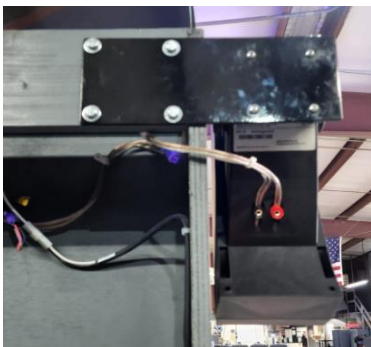

Step 11:

- Make electrical connections behind game:
 - Above each unit's control board (located on backside of Playfield Cabinet), there will be wire harnesses loosely zip-tied to the bottom of the Ramp. Starting from the back left side, cut the loose zip ties and drop the harness down and make connections into the bottom of the board. Each plug is color coded and can only be plugged into the correct receiver on the bottom of the electrical board. There may be a small black harness plug which will connect to a matching black plug near the board.

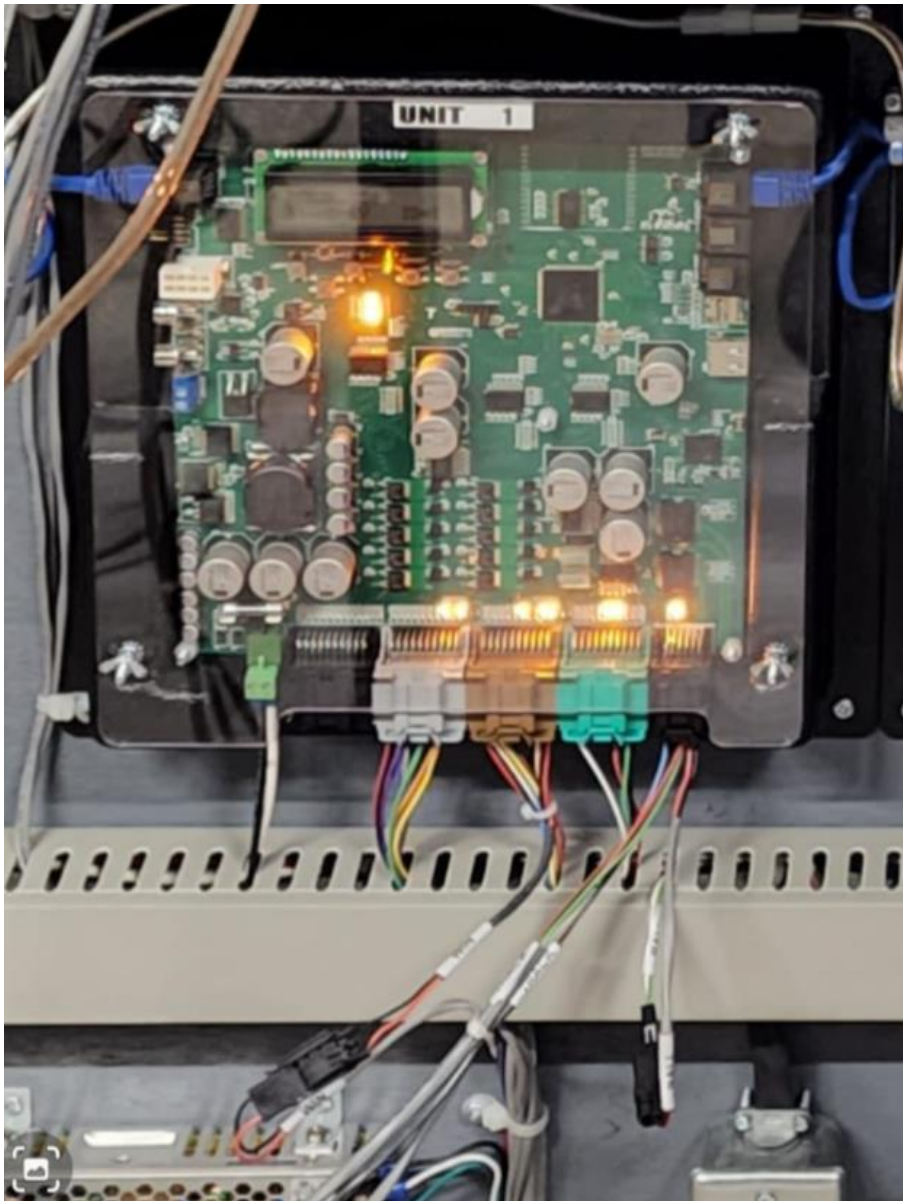

Step 11 (Continued):

- Make electrical connections behind game:
 - Connect the Player Display harness to the Display Board.
 - There will be only one Player Display Harness located in the center of the game.
 - See picture below for reference.

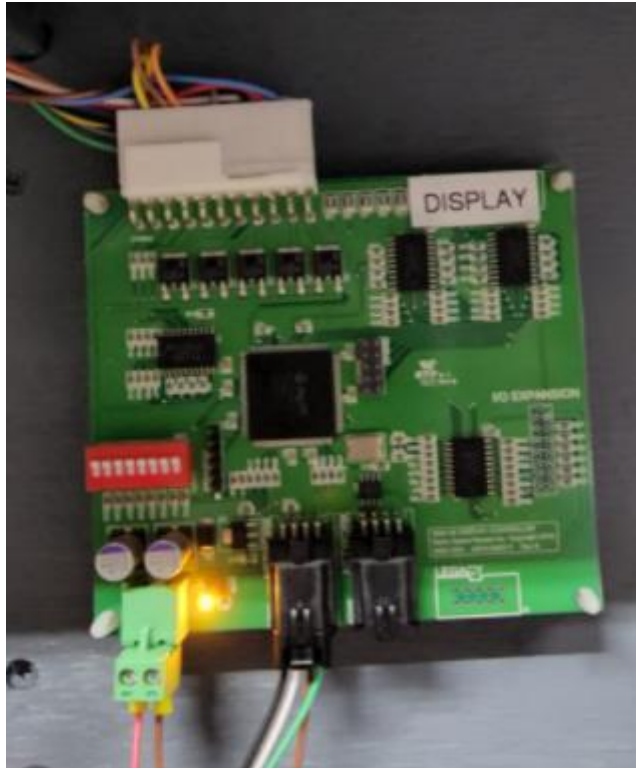

- Connect the Speaker Wires into the screw lock nuts as pictured below:
- Connect the other end of the speaker harness into the speaker cables coming from the Master Control board.



Step 11 (Continued):

- Make electrical connections behind game:
 - Connect the Sign Harness and plug the transformer into electrical outlet located on the back of the game. All plugs will be labeled and will only connect to receptacle on back of game.
 - Install the spotlight and connect power to the outlet located at the center of the game.

Step 12:

- Before plugging in game power and turning the game on; Inspect that all connections are made properly. If you are confident that all connections are made, plug the power cord into the receptacle and turn on game power.

For Technical Assistance with the Installation of the game:

Contact

Bob's Space Racers Technical Department at (386) 677-0761