



Bob's Space Racers Inc. © 1976-2020
427 Whac-A-Mole Way
Holly Hill, Florida 32117
Phone - (386) 677-0761
Fax - (386) 677-4865

BALLOON BUST™



Operator's Manual

www.bobsspacracers.com

Table of Contents

DESCRIPTION	Pg
Introduction.....	3
Overview.....	3
Safety.....	3
Power Requirements.....	3
Check Packing List.....	4
Game Setup/Installation.....	4
Operator's Procedure.....	5
Object of the game.....	5
Order of Operations.....	5
Game Types.....	5
Modes of Operation.....	5
High Score and Bonus Tickets.....	5
Linkable Game Feature.....	5
Maintenance.....	6
Troubleshooting.....	7
Troubleshooting philosophy.....	7
Recommended Troubleshooting & Testing Tools.....	7
Troubleshooting Quick Reference.....	8
Error Codes.....	8
Game Component Layouts.....	9
Electronics Schematics.....	12
Game Schematics.....	12
Programming Options.....	17
Programming Options.....	17
Setting the Programming Options.....	18
Calling For Service.....	19
Before Calling for Parts/Service.....	19
Calling for Service.....	19
Reference Information.....	19
Replacement Parts.....	20
Appendix.....	22
Appendix A: Policies.....	22
Appendix B: Warranty Information.....	22
Appendix C: Federal Communications Commission Statement.....	23
Notes.....	24

REVISION INFORMATION

REV	DATE OF REVISION	DESCRIPTION OF REVISION
A	April 14, 2022	Preliminary Draft

Introduction

Overview

This manual contains important information about the Balloon Bust attendant free game manufactured by Bob's Spacer Racers® Inc, such as: Setup, instructions how to play, maintenance, troubleshooting, game electronics and options settings, and service. Appendixes contain information about policies, warranty, and service. The Replacement parts section contains a list of commonly replaced parts on this game.

Safety

This game is powered by electricity. Improper operation or use of the this game can result in injury. DO NOT insert any foreign object(s) near any of the elctrical equipment such as fingers during operation, testing or maintenance.

USE ONLY A GROUNDED AC RECEPTACLE!

If you are unsure if your AC receptacle is properly grounded, notify a qualified electrician to perform this check. Failure to do so could result in improper operation or damage to the game and could void this product's warranty

WARNING!

Ensure that this product is compatible with your facilities power supply, voltage and frequency requirement. A label describing Electrical Specifications is attached to the product. Non-compliance with the Electrical Specifications can cause a fire and electric shock. Ensure the game is level before applying power.

Service Power Requirements

Description	Volts AC	Amps	Watts	Hertz	Units	
Game Power	110	1.6A	~150	50/60	1	
	220	.8A				

Check Packing List

Check the packing list prior to installation. Verify that all parts that have been received and are in good condition. Check the parts kit to make sure the components are in good working order. Your games parts list will differ depending on the game type.

Note: All games from Bob's Space Racers® Inc. are shipped with the same factory keys and lock sets. Bob's Space Racers® Inc. recommends changing the keys and locks on your games upon receipt.

Game Setup/Installation General

Before installation make sure the location where the game is to be installed is clean and dry. Also check to make sure the ground is level as possible and the electrical power has been installed properly for the games power requirements.

Next, be sure to read through and understand the installation manual (if applicable) before starting the installation procedure.

These games are heavy! Make sure that you have adequate help when installing this game and that everyone who is installing the game is wearing proper PPE (Personal Protection Equipment) required to install this game safely.

Make sure all components shipped with the game are easily accessible. Place the components in/on the desired location and secure all fasteners properly. Once all the pieces are in place and secured, locate the levelling shims that was shipped with the game and place them where needed to make sure the game is level.

Make sure the breakers to the games AC input power are turned off! Next make sure all power switches on the game are in the OFF position. Lastly connect the AC power input lines to their predefined AC input outlet(s).

BEFORE POWERING ON THE GAME:

- 1 Make sure all connections are properly connected.
- 2 Check all ground wires a properly fastened and secured to the component which it is installed.
- 3 Make sure all fasteners are installed and tightened securely
- 4 Check area is free of standing water
- 5 Remove any tripping/slipping hazards around the game

After all this has been completed, turn on the game power and test it for proper operation. If you are using tickets and/or card swipe systems, make sure that all settings are in place for proper operation and payout requirements.

Operator's Procedure

Object of the game

Throw the balls at the balloons to "pop" them to get as high of score as possible for tickets or prizes.

Order of Operations - Single Player

- 1 The player will activate the game by using the designated coin up device
- 2 The Ball Gate will release the balls to the player
- 3 The player will throw the balls at the targets to score points.
- 4 Once the player has used up the predetermined amount of balls or the timer has expired, the Ball Gate will close to retain the balls for the next player to use.
- 5 If the game is setup to give out tickets then at this point the game will dispense tickets to the player based on the program option settings.

Game types *These are set in the programmable options*

Type 1: Balls Per Play A player will have a predetermined amount of balls to throw at the balloons.

Type 2: Timed Game A player will have a predetermined amount of time to to throw balls at the balloons to try to pop as many as possible

Modes of Operation *These are set in the programmable options*

Attendant Free Mode This is a single player mode where the player will try to get as many points as possible to win tickets or prizes.

FEC Mode This is a multiplayer mode where players will compete against each other to see who can get to the "Win Score" first. Players will receive tickets based on the FEC Payout table setting used in program option settings.

High Ticket Mode This mode is exactly like the FEC Mode except the winning player will receive the "Winner Tickets" times the amount of players who played. The non-winning players will receive the amount of tickets based on the "Minimum Tickets" programmable option.

High Score and Bonus Tickets *Attendant Free Mode only*

The game can be setup using the programmable options to have a High Score for players to try to achieve. Once a player reaches the High Score, the player will receive the Bonus Tickets amount in addition to the amounts of tickets set using the "Points Per Ticket" programmable option. The High Score will increment as the player continues to score points during the game.

Linkable Games Feature

The game can be linked to other games of the same type so that the High Score and Bonus Tickets can be updated or achieved by the players who plays any of the linked games. The High Score will update on the High Score display if any of the players surpass the high score on games that are linked together.

This information will also be displayed on the LED Dot Matrix display attached to the game (if equipped) along with player winner information and other operation information.

Maintenance

WARNING!

Always ensure power is off and fully disconnected from power source when performing routine or in-depth maintenance. Failure to do so can result in damage to the game or injury to personnel.

There is not much maintenance needed on this game however Bob's Space Races Inc. does recommend cleaning the game daily using a soft microfiber towel and a non-abrasive cleaner.

You will also want to clean the sensor cover assemblies to remove any dirt, debris and/or finger prints that may be on the sensor cover assembly. This will ensure a better reading from the "Ball Tracking Sensors".

Troubleshooting

Troubleshooting Philosophy

- 1 Always check to be sure that your game power is turned on. Ensure that all of the fuses in the game are functional and that the AC voltage is in the proper operating range for your game.
- 2 Ensure that all of the game harnessing is plugged in properly and that all of the pins are firmly seated in the connectors. It is always possible that a harness can be damaged by rough shipping or moving.
- 3 Inspect game harnessing to be sure that none of the wires have become or are damaged. Utilize a handheld multi-meter, and check continuity of the wires to make sure they are not broken.
- 4 Inspect for obvious damage to the P.C. Boards or electrical components.
- 5 If you have multiple similar games or multiple parts for a game, swap or exchange the parts to see if the problem goes away or moves to another location. You can quickly eliminate certain parts as being the problem within the game.
- 6 When changing electronic or electrical components, ALWAYS turn off all external power and unplug the game.
- 7 Ensure that all power supplies are delivering the specified voltages to the P.C. Boards and components as shown in the manual.

Recommended Troubleshooting & Testing Tools

These are the tools that Bob's Space Racers recommends you keep in/near your game for troubleshooting and repairing game as quickly as possible. These tools can be purchased from most hardware and department stores.

- 1 #2 Phillips (Star) type screw driver
- 2 #2 Flat blade type screw driver
- 3 #2 Square tip screw driver
- 4 Wire cutters
- 5 Wire strippers
- 6 Standard and Metric Hex Head wrenches
- 7 Standard and Metric socket and ratchet set
- 8 Standard and Metric open end wrench set
- 9 Digital Multimeter with backlight
- 10 Flashlight (head light preferred)
- 11 Electrical connector crimpers
- 12 Tool Bag/box
- 13 Electrician gloves
- 14 Silicon based spray lubricant
- 15 Assorted set of wire splice connectors, wire ties, heat shrink tubing, and electrical tape

Troubleshooting Quick Reference

- 1 The game does not register the correct amount of balls thrown in the game.**
 - a. Make sure the sensor cover assemblies are clean and free of any dirt, debris or finger prints.
 - b. Make sure the Ball Tracking Sensor harnesses are securely connected to the main logic board
 - c. Make sure the Ball Tracking Sensor harnesses are connected to the sensor assemblies

- 2 The game does not register points when the player successfully hits the target.**
 - a. Make sure the Ball Tracking Sensor Assemblies are working properly
 - b. Check the connection to the target sensors
 - c. Make sure the target plex cover is not stuck and is able to freely move to hit the target sensor
 - d. Adjust the target sensors to make sure they come in contact with the target magnet on the bottom of the target cover plex
 - e. Make sure the target magnet is correctly installed in the bottom of the target cover plex assembly

- 3 The Ball Gate does not move when the game is initialized (coined up)**
 - a. Make sure the Ball Gate Actuator is properly connected to the main harness assembly
 - b. Make sure nothing is inhibiting the Ball Gate from lowering
 - c. Power cycle the game

ERROR CODES - LED DISPLAY

Er1 The game is out of tickets

Ert One of the targets is activated when the game is idle

ERROR CODES - MAIN LOGIC BOARD

TARGET ERROR One or more of the targets are activated when the game is idle

COMM ERROR One or more of the units are not properly connect to the games network

Game Component Layout - Isometric View

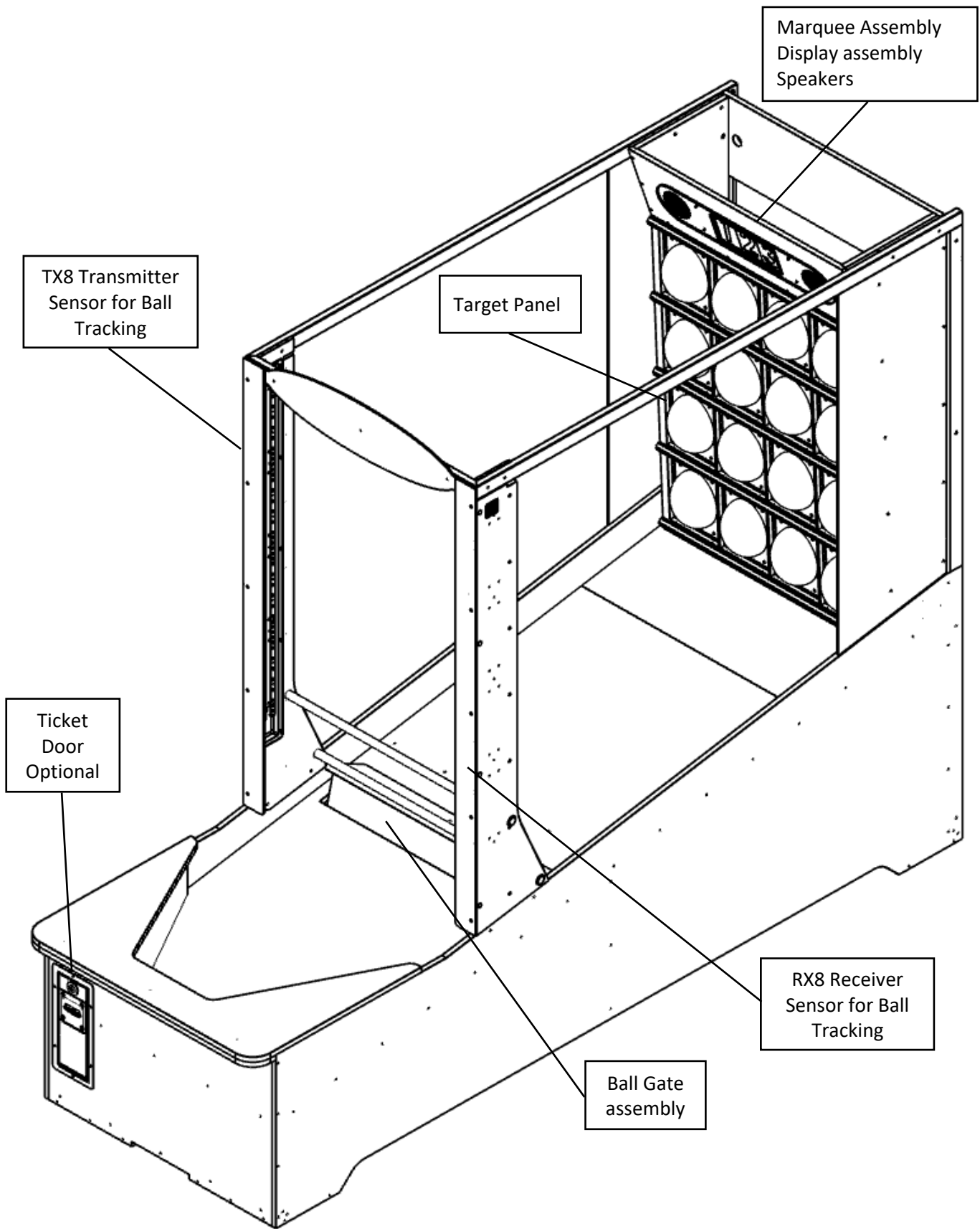

Game Component Layout - Side View

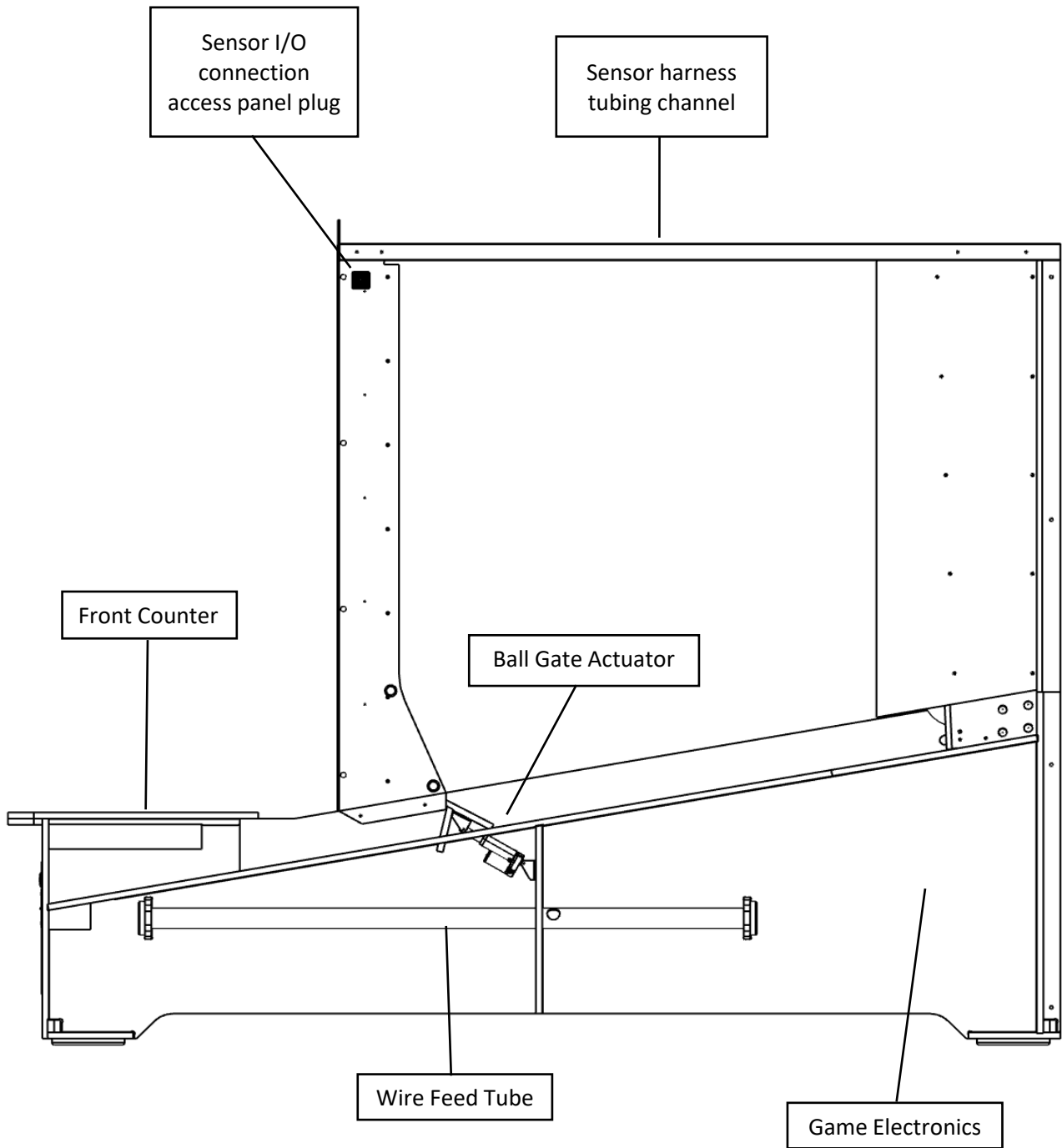

Game Component Layout - Rear View

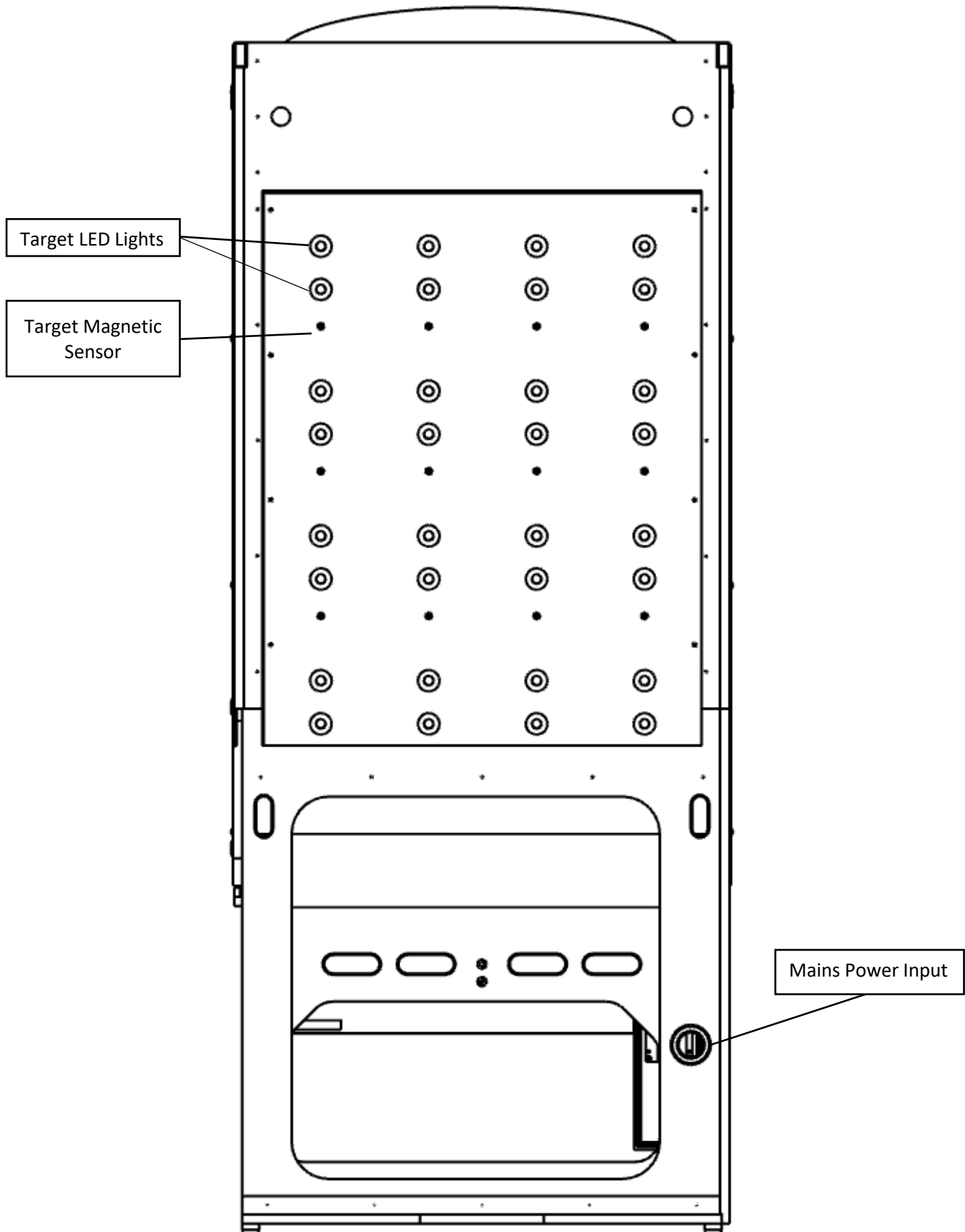

Electronics Schematics

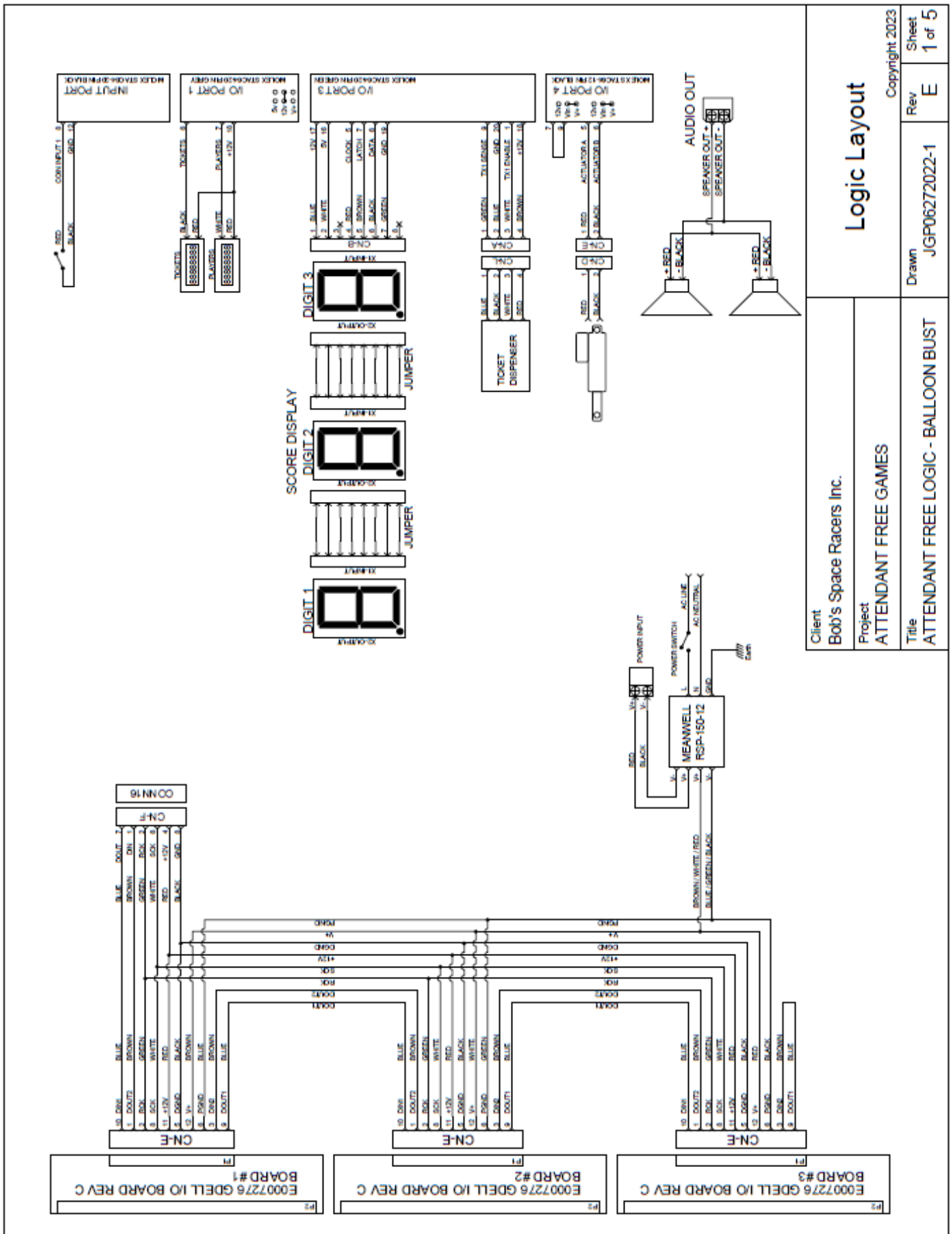

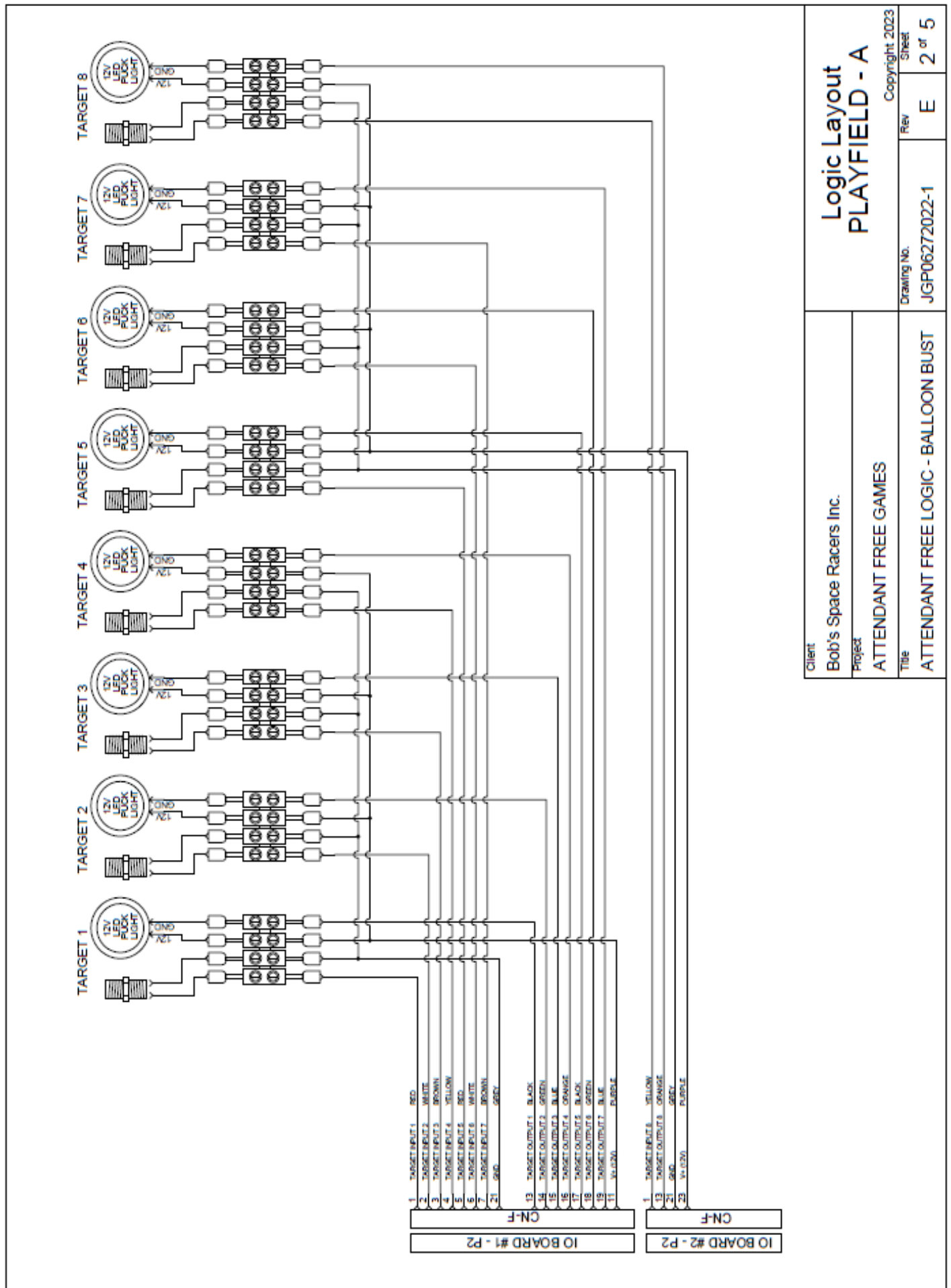

Client	Bob's Space Racers Inc.		
Project	ATTENDANT FREE GAMES		
Title	ATTENDANT FREE LOGIC - BALLOON BUST		
Drawing No.	JGP06272022-1	Rev	E
Copyright 2023	Sheet	2 of 5	

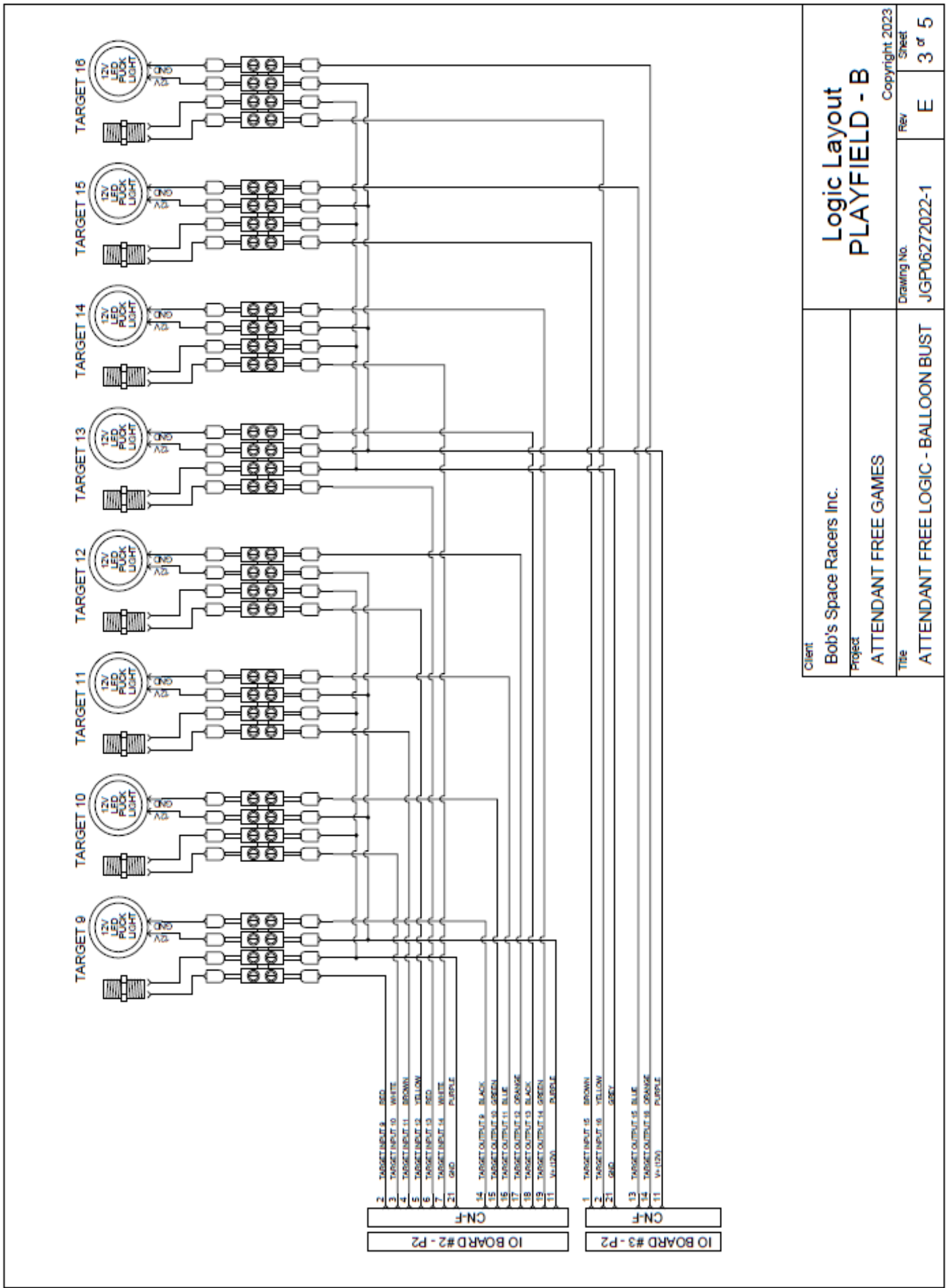

Client	Bob's Space Racers Inc.	Copyright 2023
Project	ATTENDANT FREE GAMES	Sheet
Title	ATTENDANT FREE LOGIC - BALLOON BUST	Rev
	JGFP06272022-1	E
		3 of 5

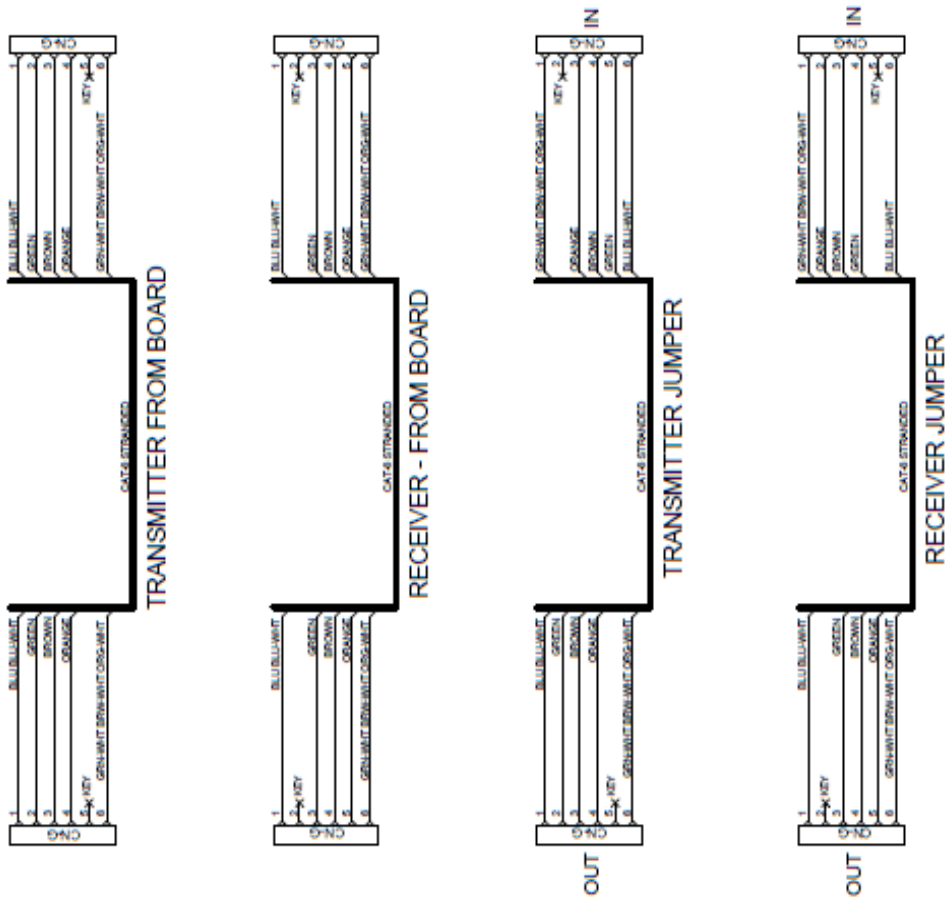

LEFT - FRONT VIEW RIGHT - FRONT VIEW

Client Bob's Space Racers Inc.	Sensor Layout	Copyright 2023
Project ATTENDANT FREE GAMES		Rev Sheet E 4 of 5
Title ATTENDANT FREE LOGIC - BALLOON BUST		Drawn JGP06272022-1

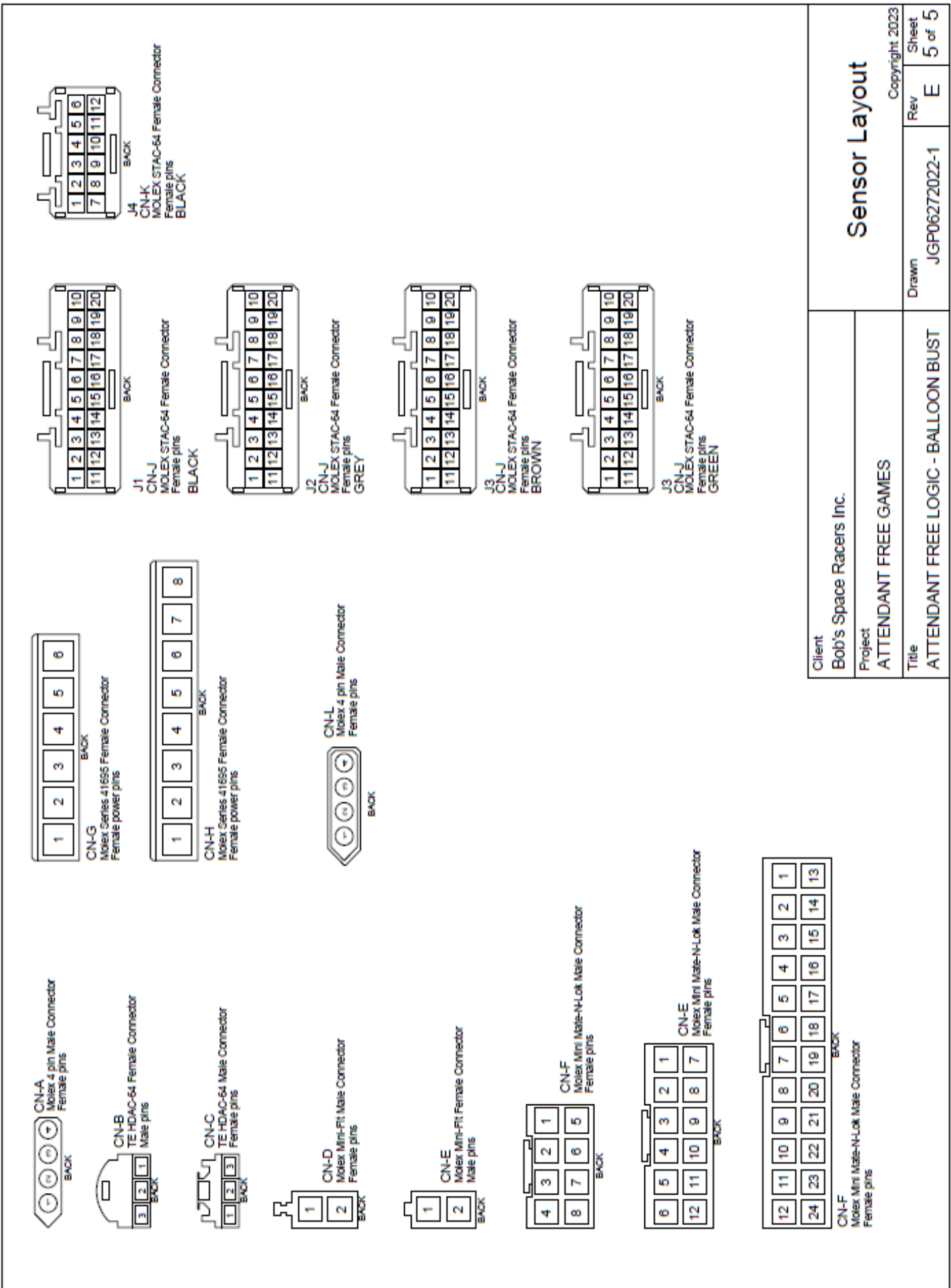

Programming Options

ATTENDANT FREE MODE PROGRAM OPTIONS

UNIT ID	Units player number location		0	32
GAME MODE	Mode A (0) = Attendant Free	0	0	3
GAME TIME	Amount of time for the player to play (<i>time in seconds</i>)	30	0	180
ATTRACT TIME	Amount of time the audio barker will sound off (<i>in minutes</i>)	10	0	10
COST PER PLAY	Amount of credits needed to coin up a player (<i>coin input only</i>)	2	1	8
MONEY PROMPT	Not Used	0	0	2
WIN LITE TIME	Amount of time the beacon/win lite stays on for (<i>time in seconds</i>)	4	1	12
STACK CREDITS	0 = Do not stack credits 1 = Allow game to stack credits	1	0	1
WIN SCORE	Amount of points needed to win the game	1	0	100
BALLS PER PLAY	Amount of balls the player is given to play <i>Note if this is set to '0', the game will be a timed game based on the GAME TIME program option</i>	3	0	25
HIGH SCORE	Score value for players to achieve to win the BONUS TICKETS	0	0	100
POINTS-PER-TICKET	Amount of tickets given per point value divider	1	0	100
BONUS START	Amount of tickets given for surpassing the HIGH SCORE starting v	0	0	300
BONUS ADDER	Amount of tickets added to the BONUS if the player doesn't surpass the HIGH SCORE.	0	0	100
BONUS MAX	Maximum amount of tickets given for surpassing the HIGH SCORE	0	0	990
MINIMUM TICKETS	Amount of tickets given for just playing the game if not points gained	0	0	100

FEC/GROUP MODE ONLY PROGRAM OPTIONS

UNIT ID	Units player number location		0	32
GAME MODE	Mode B (1) = FEC Mode Mode D (3) = Group mode	1	0	3
GAME TIME	Amount of time for the player to play (<i>time in seconds</i>)	30	0	180
ATTRACT TIME	Amount of time the audio barker will sound off (<i>in minutes</i>)	10	0	10
COST PER PLAY	Amount of credits needed to coin up a player (<i>coin input only</i>)	2	1	8
MONEY PROMPT	Shows what type of coin up is required on marquee 0 = SWIPE CARD TO PLAY 1 = INSERT CARD TO PLAY 2 = GET READY	0	0	2
WIN LITE TIME	Amount of time the beacon/win lite stays on for (<i>time in seconds</i>)	4	1	12
STACK CREDITS	0 = Do not stack credits	1	0	1
WIN SCORE	Amount of points needed to win the game	15	1	100
WINNER TICKETS	Amount of ticket player received (<i>See FEC PAYOUT TABLE</i>)	1	0	12

		Amount of players in the game											
		1	2	3	4	5	6	7	8	9	10	11	12
Program Option	0	0	0	0	0	0	0	0	0	0	0	0	0
	1	0	1	1	1	1	1	2	2	2	2	2	3
	2	0	1	1	1	2	2	2	2	3	3	3	3
	3	0	1	1	2	2	2	3	3	3	4	4	4
	4	0	1	2	2	2	3	3	3	4	4	4	4
	5	0	1	2	2	2	3	3	4	4	4	4	4
		Amount of tickets received to winner											

FEC Winner Ticket Payout Table

HIGH SCORE MODE ONLY PROGRAM OPTIONS

UNIT ID	Units player number location		0	32
GAME MODE	Mode C (2) = HIGH TICKET Mode	2	0	3
GAME TIME	Amount of time for the player to play (<i>time in seconds</i>)	30	0	180
ATTRACT TIME	Amount of time the audio barker will sound off (<i>in minutes</i>)	10	0	10
COST PER PLAY	Amount of credits needed to coin up a player (<i>coin input only</i>)	2	1	8
MONEY PROMPT	Shows what type of coin up is required on marquee 0 = SWIPE CARD TO PLAY 1 = INSERT CARD TO PLAY 2 = GET READY	0	0	2
WIN LITE TIME	Amount of time the beacon/win lite stays on for (<i>time in seconds</i>)	4	1	12
STACK CREDITS	0 = Do not stack credits 1 = Allow game to stack credits	1	0	1
WIN SCORE	Amount of points needed to win the game	15	1	100
WINNER TICKETS	Amount of ticket player received times players who played	100	0	300
MINIMUM TICKETS	Amount of tickets given for just playing the game if not points gained	0	0	100

Setting the Programming Options

WARNING!

Inadvertently, changing program settings can cause undesirable results to your game. Bob's Space Racers® Inc. has set these options to achieve the highest turn-around time and optimal game

- 1 Locate the main logic board in your game. *This is located in the back of the game.*
- 2 Press and hold down the SELECT and ENTER buttons for about 4 seconds to enter program mode.
- 3 Press either UP or DOWN to scroll through the options
- 4 Press either LEFT or RIGHT to change the options value. *Setting the value saves it automatically*
- 5 Press the SELECT button to exit programming mode.

Note: while programming, the main logic board has a timed limit and if left idle, the master board will exit the programming mode with the current settings saved.

Programming Section of the Main Logic board.

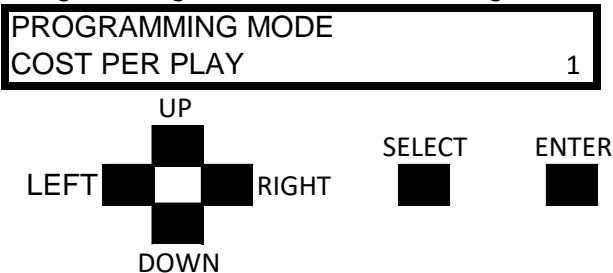

RESETTING TO THE FACTORY DEFAULTS

To reset the main logic board back to factory defaults settings, turn the game off, press and hold the ENTER button and turn the game power back on. Make sure you keep holding the ENTER button until you see the UNIT ID change to '33'. Enter programming mode to set the UNIT ID to '1' so that the board will operate properly.

CHANGING THE GAME TYPE

You wouldn't normally have to do this but in the event that it is required to change the board to another game type: Turn the game power off, press and hold the UP and LEFT button and turn the game power back on. The screen will display the game type the board is currently set to. Select the game type by pressing left or right and then pressing SELECT when you are finished.

Calling For Service

Before Calling For Service/Parts

Make sure you check this manual for troubleshooting tips as your solution may already be present in this manual

Make sure you have the serial number of the game and a proof of purchase as this will be requested for warranty issues.

If you are calling for assistance on troubleshooting make sure you are at your game with the recommended tools ready.

Calling For Service/Parts

If this is a repeat call, please tell the service technician or customer service person that you have made a previous call regarding this game.

If you are calling to order a part(s) please refer to the "Replacement Parts" section of this manual and have the part number ready if available. This will speed up the ordering process.

If you are ordering an electronic board that has a program in it, please have the program name and revision available. This is located on the main logic boards LC Displays or a sticker attached to one of the main logic boards.

Depending on the age of your game and the part you need, you may be requested to send a picture to Bob's Space Racers so that we make sure you get the correct part. This can be done using your smart phone and send the picture via text to our parts email address parts@bsrgames.com

Reference Information

Game Name: _____

Purchase Date: _____

Serial Number: _____

Program Number: _____

Replacement Parts

EM080318-FEC	BSR-300- FEC MAIN LOGIC BOARD	
ARWB2002	SENSOR MAGNETIC	
H0018389	MAGNET FOR TARGETS	
E0007276	BOARD STATION I/O	
E0022720	CS-POWER SUPPLY 12V 12.5AMP	
E0800038	ACTUATOR LINEAR 12V - AFG BALLOON BUST - BALL STOP	
EM040743	3 DIGIT 4IN DISPLAY DELL	
E0029023	12V LED PUCK LIGHT WHITE WITH WIRES	
M0004571-S	AFG BALLOON BUST BALLS	

PRSAAF032	SENSOR ARRAY ASSY-RECIEVER-AFG	
PRSAAF034	SENSOR ARRAY ASSY-TRANSMITTER-AFG	
EM080320	EXPANSION HEADER - SENSOR	
PRBBAF106	DOOR TARGET - BALLOON BUST AFG (SPECIFY COLOR)	
TBD	MAIN GAME LOWER HARNESS	PICTURE TBD
TBD	MAIN GAME UPPER HARNESS	PICTURE TBD
M0020350	TICKET DISPENSER 2x4IN TICKETS ONLY	
M0800204	TICKET DISPENSER 1x2IN TICKETS ONLY	
m0008600	TICKET 2IN X 4IN "YOU'RE A WINNER"	

Appendixes

Appendix A: Policies

Service Policy

Here at BOB'S SPACE RACERS® INC., we pride ourselves in providing the highest quality, long lasting, and easy to maintain equipment.

Technical Support Service hours are from 8:30 am to 5:00 pm, EST, Monday through Friday, excluding holidays. The direct phone number is (386) 677-0761 ext:146. During all other times, follow the prompts on our Automated Phone System to relay your problem to the technician on call. You may also contact Technical Support through our website or by email at tech@bobsspacracers.com. Technical Support will assist you in troubleshooting a service problem or setting equipment options.

Note that if your game is not under warrant, you may be charged for the call!

Customer Service hours are from 8:30 am to 5:00 pm, EST, Monday through Friday, excluding holidays. Customer Service staff can be reached at (386) 677-0761, through our website or by email at parts@bsrgames.com. They will also take parts orders and research the status of current or previous orders.

Replacement Policy

After speaking with our Technical Support department or Customer Service department, it may be necessary for Bob's Space Racers® Inc., to ship an assembly item or part to repair your game. Upon shipment of the new item(s) a Return Merchandise Authorization Number (RMA #) will be issued for you to use when returning the defective item(s) to Bob's Space Racers® Inc. You may also use your order number for the new assembly/part as an RMA number. After the defective item(s) is received by Bob's Space Racers® Inc. your account will be issued either a:

Warranty Credit: if your game is still under warranty. *See warranty policy*
or

Core Credit: This credit is 20% of the purchased priced for the item(s).

Note: These credits do not include shipping charges of any kind!

Appendix B: Warranty

BOB'S SPACE RACERS® INC. © 1976-2020

1 YEAR GAME WARRANTY

INCLUDED IN THIS WARANTY Bob's Space Racers® Inc., warrants to the original purchaser only that the equipment that is the subject of this sale conforms to its specifications, and is free from defects under normal service for 120-Days period from the original date of deliver. This warranty does not include any damages resulting from occurrences listed in paragraph 2 below. This warranty is not transferable under any circumstance. Any claims under this warranty must be received in writing by Bob's Space Racers® Inc. within 120-days from date of delivery. Within a reasonable time of such written notification Bob's Space Racers® Inc. will replace or repair any defective component of the equipment or part thereof which fails for reasons other than normal service, use, or wear. Bob's Space Racers® Inc. reserves the right to request dated proof of purchase by the end user (original purchaser) at any time. Bob's Space Racers® Inc., within its sole discretion, makes the final determination as to whether to repair or replace any component and whether any such repair or replacement shall be performed where the equipment is located or at its home facility in Volusia County, Florida, or another facility of its sole choice. Any and all freight charges for the purposes of repair or replacement shall be paid by the original purchaser. All defective parts shall be returned to Bob's Space Racers® Inc. if requested. Bob's Space Racers® Inc. does not warrant that the equipment will meet any original purchaser's specific requirements or that the operation of the equipment will be uninterrupted. These remedies are the original purchaser's exclusive remedies for breach of warranty.

EXCLUDED BY THIS WARRANTY Bob's Space Racers® Inc. does not warrant (a) any product, components or parts not manufactured by Bob's Space Racers® Inc.; light bulbs are excluded and shall be the sole responsibility of the purchaser; (b) damages caused by use of the equipment for purposes other than those for which it was designed; (c) defects caused by failure to provide a suitable installation environment for the equipment; (d) damage caused by unauthorized attachments, modification, or service; damage caused by normal wear and tear or improper power supply; (f) damage caused by accident or disaster such as fires, flood, lightning, and wind; or (g) any other abuse or misuse of the equipment.

EXCLUSIVE WARRANTY. THE FORGOING WARRANTY IS EXCLUSIVE AND IN LIEU OF ALL OTHER WARRANTIES OR REMEDIES, WHETHER WRITTEN, ORAL OR IMPLIED. THERE ARE NO WARRANTIES WHICH EXTEND BEYOND THE DESCRIPTION ON THE FACE HEREOF. ANY AND ALL IMPLIED WARRANTIES OF MERCHANTABILITY, FITNESS FOR A PARTICULAR PURPOSE, COURSE OF DEALING OR USAGE OF TRADE ARE HEREBY EXPRESSLY DISCLAIMED AND EXCLUDED.

REMEDIES LIMITED. UNDER NO CIRCUMSTANCES, EXCEPT TO THE EXTENT PROHIBITED BY APPLICABLE LAW, SHALL BOB'S SPACE RACERS® INC. BE LIABLE FOR ANY LOSS OR DAMAGE, DIRECT OR INDIRECT, SPECIAL INCIDENTAL OR CONSEQUENTIAL ARISING OUT OF THE USE OR INABILITY TO USE THIS EQUIPMENT INCLUDING BUT NOT LIMITED TO ANY CLAIM FOR LOSS OR PROFITS, LOSS OF SAVINGS OR REVENUE, LOSS OF USE OF THE EQUIPMENT, OR ANY ASSOCIATED EQUIPMENT, FACILITIES OR SERVICE, DOWNTIME, THE CLAIMS OR COSTS OF THIRD PARTIES INCLUDING CUSTOMERS AND INJURY TO PROPERTY. Some states do not allow limitations on how long an implied warranty lasts or the exclusion or limitation of incidental or consequential damages, so the above limitations or exclusion may not apply to you. This warranty gives you specific legal rights, and you may also have other rights which vary from state to state.

NO OTHER WARRANTIES. Unless modified in writing and signed by both parties, this agreement is understood to be the complete and exclusive agreement between the parties, superseding all prior agreements, oral or written, and all other communications between the parties relating to the subject matter of this agreement. No employee or representative of Bob's Space Racers® Inc. or any other party is authorized to make any other warranty or to assume any other liability in connection with the sale of its equipment.

TIME LIMIT FOR CLAIMS. Any claim for breach of warranty or claims under this warranty must be received in writing by Bob's Space Racers® Inc. within 90-days following delivery of the equipment.

ALLOCATION OF RISKS. This agreement allocates the risks of equipment failure between Bob's Space Racers® Inc. and the original purchaser. This allocation is recognized by both parties and is reflected in the price of the goods. THE PURCHASER ACKNOWLEDGES THAT HE HAS READ THIS AGREEMENT, UNDERSTANDS IT, AND IS BOUND BY ITS TERMS.

TO OBTAIN WARRANTY SERVICE. The original purchaser must, at his/her own expense, bring or ship the equipment to an authorized location for service. Additionally, the original purchaser must pay all freight, shipping or transportation charges for the return of the equipment from Bob's Space Racers® Inc. to the original purchaser.

Replacement Item(s) Shipping Requirements

When you request an Advanced Replacement item from us, we recommend you to follow these criteria:

DO NOT try to repair the defective item(s) on your own; DO NOT disassemble the defective item(s) prior to returning it to Bob's Space Racers® Inc. – this could cause further damage and the possibility of you not receiving any credit at all on the item(s). There are no user serviceable parts contained within, and our vendors may void their warranty on disassembled parts.

Wait for the Replacement item(s) to arrive prior to returning the defective item(s).

When the Replacement item(s) arrive, verify that it is the correct part. If it is not, please note what the differences are and contact Bob's Space Racers® Inc. at 386-677-0761.

Return the defective item(s) in the exact same packaging the Replacement item(s) came in. This insures no more damage will be done to the item(s) during the return shipping.

Thank You!

Appendix C: Federal Communications Commission Statement

This equipment has been tested and found to comply with limits for a Class A digital device, pursuant to part 15 of the FCC Rules. These limits designed to provide reasonable protection against harmful interference when the equipment is operated in a commercial environment. This equipment generates, uses, and can radiate frequency energy, and, if not installed and used in accordance with the instruction manual may cause harmful interference to radio communications. Operation of this equipment in a residential area is likely to cause harmful interference in which case the user will be required to correct the interference at his/her own expense.

This page is intentionally left blank.



Bob's Space Racers Inc. © 2020

427 Whac-A-Mole Way

Holly Hill, Florida 32117

Phone - (386) 677-0761

Fax - (386) 677-0794

Technical Support Email: tech@bobsspaceracers.com

Parts Dept. Email: parts@bsrgames.com